

Table of Contents for Heavy Duty Extra Long Poly Blade

Arctic Heavy Duty Poly Blade 90" & 96" (Blade, Quadrant & A-frame)..... 2
Power angling installation..... 7
Shock absorber installation 12
Pro-Wings installation..... 15
Extension Angle..... 19

Important note:

Lift frames for this specific blade are listed below:

- Lift Frame QLII-HI-DLC-GA
- Lift Frame QLIII-HI-DLC-GA
- Lift Frame QLIIV-HI-DLC-GA

For more information about the lift frame, check under Lift frame section

Arctic Heavy Duty Poly Blade 90" & 96"
Arctic Heavy Duty XL Poly Blade 102" &
108"

ARCTIC HEAVY DUTY POLY BLADE 90" & 96" ARCTIC HEAVY DUTY XL POLY BLADE 102" & 108" (BLADE, QUADRANT & A-FRAME)

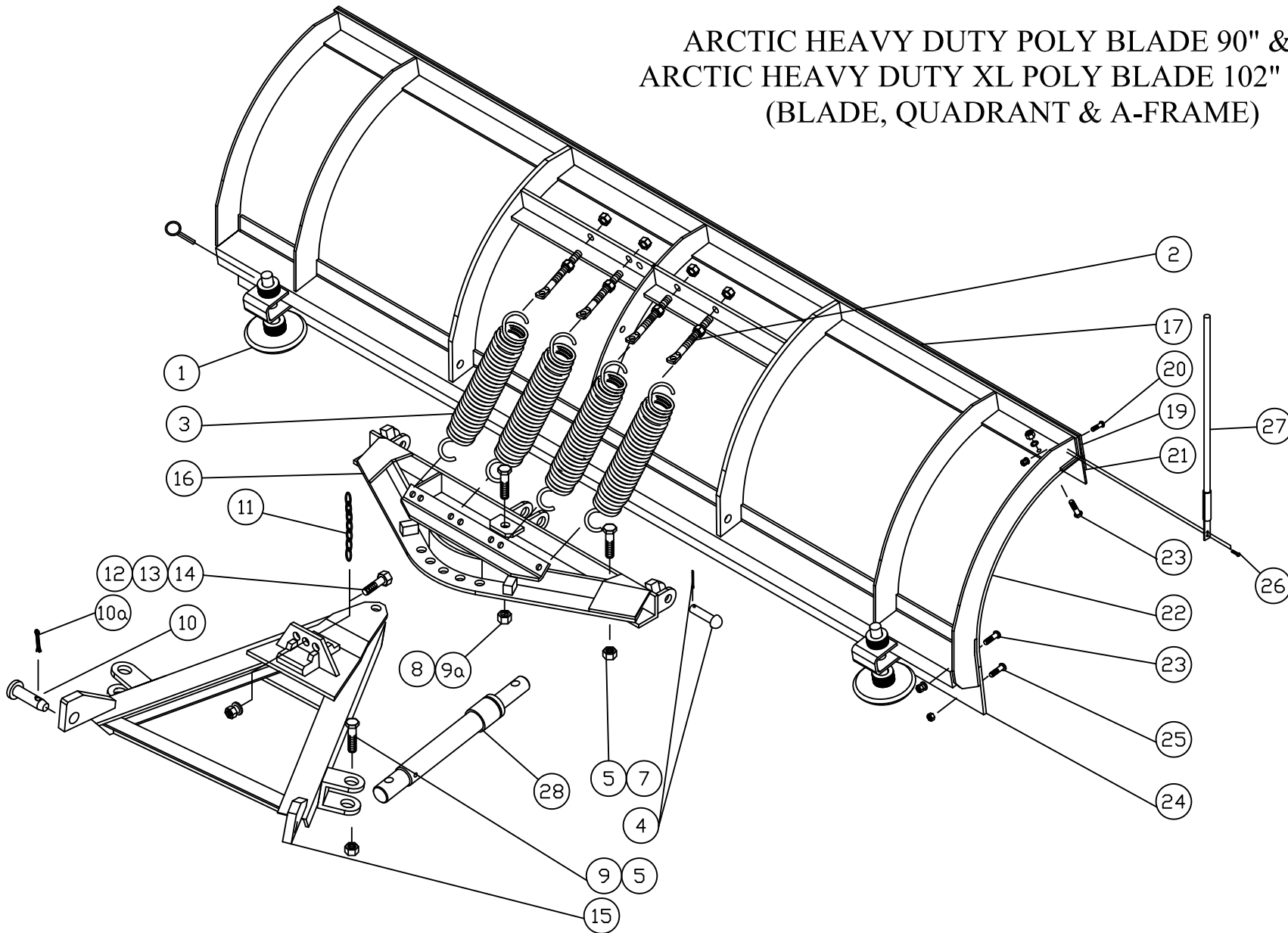

 Warning

Do not exceed GVWR or GAWR, including blade and ballast. The rating label is found on the driver side vehicle door corners.

Lower the blade when the vehicle is parked. Temperature changes could change hydraulic pressure, causing the blade to drop unexpectedly or damaging hydraulic components. Failure to do this can result in serious personal injury.

Servicing the trip springs without special tools and knowledge could result in personal injury. See Arctic authorized dealer for service.

Inspect snowplow components and bolts for wear and damage when mounting or removing snowplow and before traveling.

Keep hands and feet clear of the blade, A-frame and cylinders when mounting or removing the snowplow. Moving or falling assemblies could cause personal injury. Never use a finger to check an alignment. Moving or falling assemblies could crush your finger.

Do not stand between the vehicle and the blade or within 10' of a moving blade. A moving or falling blade could cause personal injury.

To prevent accidental movement of the blade, always turn the control OFF whenever the snowplow is not in use.

Arctic HD-P (90", 96") & Arctic HDXL-P (102" & 108") Blade, A-frame & Quadrant Galvanized			
Item	Part Number	Description	Quantity
1	50037-B-GA	Shoe Assembly Galvanized	2
1a	50040-A	Lynch Pin	1
1b	55017-N	Shoe Washers	24
1c	50666-B-GA	Shoe Galvanized	1
2	50191-M	Eye bolt Assembly	4
3	50180-C	Trip Spring	4
4	50232-M	3/4" x 3" Rivet Assembly	3
5	HH-00973-007	3/4" Hex Nut Nylon Insert	4
7	HH-00972-153	3/4" x 3.1/2" UNF Cap screw	2
8	HH-00540-003	3/4"-16 Nylon insert locknut	1
9	HH-00972-152	3/4" x 3.1/4" UNF Cap screw	3
9a	53600-0005	3/4" x 4" UNF Cap screw G8	
10	53325-A	Spreader Pin	2
10a	HH-00020-164	Cotter pin	2
11	55018-02-M	Lift Chain - QLI, QUIK*LINK® II	1
	55018-M	Lift Chain - Hi Boy	
12	HH-00972-090	1/2" x 1 1/2" UNF Cap screw	1
13	HH-00457-001	1/2" Lock washer	1
14	HH-00460-002	1/2" UNF Hex nut	1
15	50656-D-GA	32" A-Frame	1
16	52272-M-GA	Poly Quadrant	1
17	52264-M-GA	Blade Assembly - 90" (includes skin, cutting edge, deflector, shoes)	1
	52265-M-GA	Blade Assembly - 96" (includes skin, cutting edge, deflector, shoes)	
	52266-M-GA	Blade Assembly - 102" (includes skin, cutting edge, deflector, shoes)	
	52267-M-GA	Blade Assembly - 108" (includes skin, cutting edge, deflector, shoes)	
18*	52298-M-GA	Optional Shock Absorber Assembly	1
19	52239-M-GA	Deflector Strap - 90"	1
	52240-M-GA	Deflector Strap - 96"	
	52241-M-GA	Deflector Strap - 102"	
	52279-M-GA	Deflector Strap - 108"	
20	52288-M	Deflector Bolt Kit 90"/96"/102"	1
	52289-M	Deflector Bolt Kit 108"	
21	52245-M	Deflector - 90"	1
	52246-M	Deflector - 96"	
	52247-M	Deflector - 102"	

Arctic HD-P (90", 96") & Arctic HDXL-P (102" & 108") Blade, A-frame & Quadrant Galvanized			
Item	Part Number	Description	Quantity
	52280-M	Deflector - 108"	
22	52228-02-D	Blade Skin - 90" (orange)	1
22	52228-02-D-PLAT	Blade Skin - 90" (gray)	
	52228-03-D	Blade Skin - 96" (orange)	
	52228-03-D-PLAT	Blade Skin - 96" (gray)	
	52228-04-D	Blade Skin - 102" (orange)	
	52228-04-D-PLAT	Blade Skin - 102" (gray)	
	52277-D	Blade Skin - 108" (orange)	
	52277-D-PLAT	Blade Skin - 108" (gray)	
23	55013-N	Blade Skin Bolt, Lock Washer & Nut (90",96",102")	16
	55013-N	Blade Skin Bolt Washer & Nut (108")	18
24	52233-M	Cutting Edge - 90"	1
	52234-M	Cutting Edge - 96"	
	52235-M	Cutting Edge - 102"	
	52236-M	Cutting Edge - 108"	
25	52593-8-M	½" x 1 ¾" Carriage Bolt Assembly(90",96",102")	Pack of 8
	52593-10-M	½" x 1 ¾" Carriage Bolt Assembly (108")	Pack of 10
26	GB001	Guide Bolt Assembly	4
27	50999-B	Blade Guide	2
28	CS150-10.00-NRS	Cylinder 1 ½" x 10"	2

Arctic Equipment Manufacturing Corporation reserves the right under its product improvement policy to change construction or design details and furnish equipment when so altered without reference to illustrations or specifications used.

Arctic HD & HDXL Poly Blade, Quadrant & A-frame Installation

Warning

Do not exceed GVWR or GAWR, including blade and ballast. The rating label is found on the driver side vehicle door corners.

Warning

Lower the blade when the vehicle is parked. Temperature changes could change hydraulic pressure, causing the blade to drop unexpectedly or damaging hydraulic components. Failure to do this can result in serious personal injury.

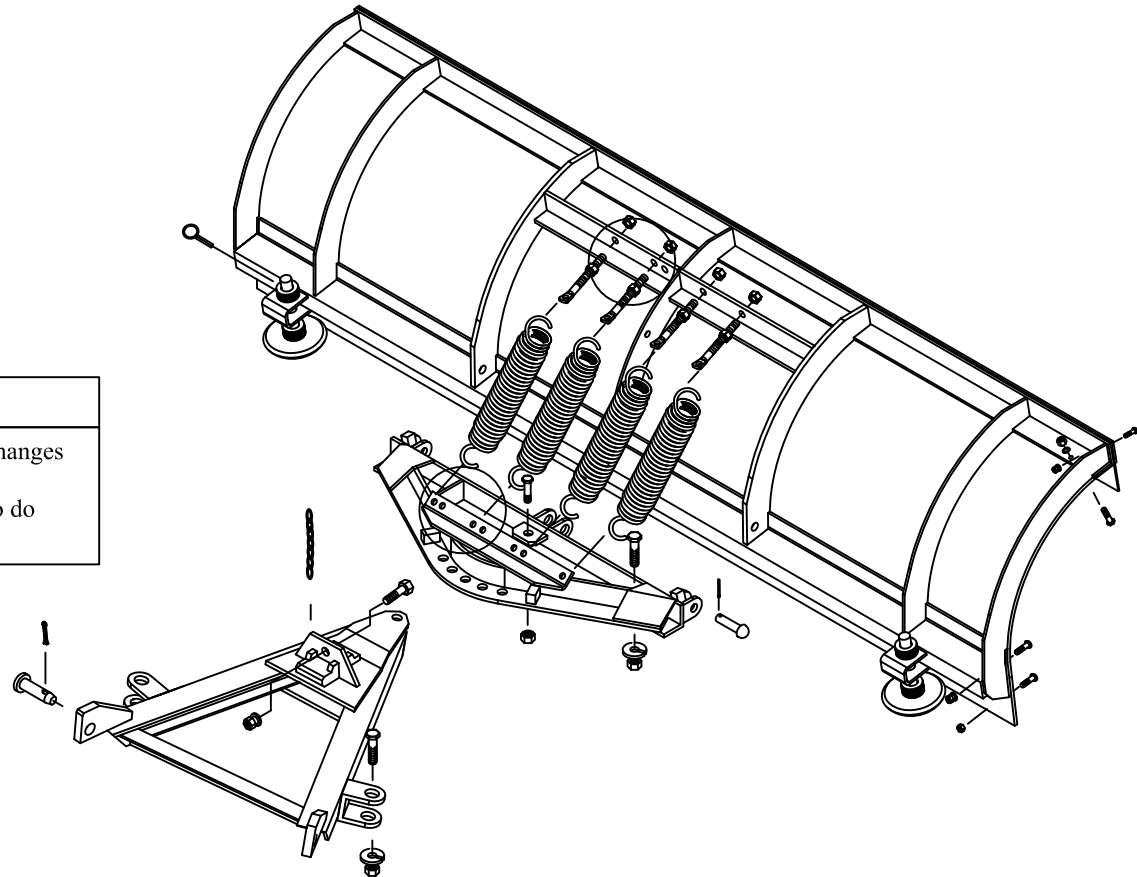

Warning

Inspect snowplow components and bolts for wear and damage when mounting or removing snowplow and before traveling.

Warning

Keep hands and feet clear of the blade, A-frame and cylinders when mounting or removing the snowplow. Moving or falling assemblies could cause personal injury. Never use a finger to check an alignment. Moving or falling assemblies could crush your finger.

Warning

Do not stand between the vehicle and the blade or within 10' of a moving blade. A moving or falling blade could cause personal injury.

ARCTIC HD & HDXL POLY BLADE, QUADRANT & A-FRAME INSTALLATION

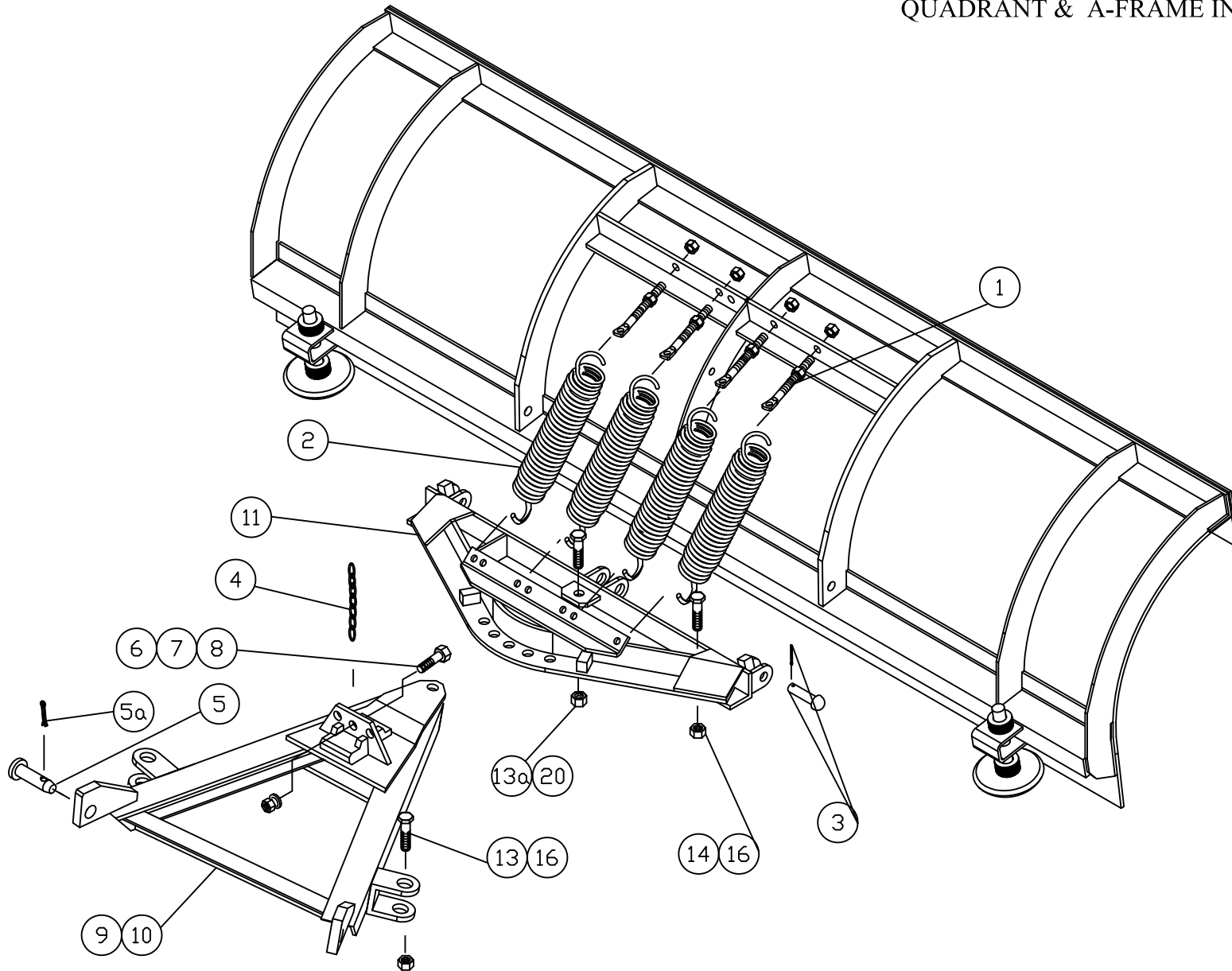

Hardware Kit Heavy Duty Poly Blade					
Item	Part#	Description	Hardware Kit 52275-01-M	Hardware Kit 52275-02-M	Hardware Kit 52275-03-M
1	50191-M	Eye Bolt Assembly (eye bolt 5/8" hex nuts)	4		
2	50180-C	Trip Spring	4		
3	50232-M	3/4" x 3" Rivet Assembly (includes cotter pin)	3		
4	55018-02-M	Chain 30"		1	
	55018-M	Chain 40"	1		2
5	53325-A	Spreader Bar Pin	2		
5a	HH-00020-164	Cotter pin	2		
6	HH-00972-090	1/2-20 x 1.1/2 Hex Head Cap Screw	1		2
7	HH-00460-002	1/2-20 Hex Nut	1		2
8	HH-00457-001	1/2 Lockwasher	1		2
Power Angling Assemblies Heavy Duty poly Blade 52273-M-GA & 52274-M-GA					
Item	Part #	Description	52273-M-GA	52274-M-GA	
9	50656-D-GA	32" A-Frame		1	
10	50730-D-GA	28" A-Frame	1		
11	52272-M-GA	Quadrant	1		
12	CS150-10.00- NRS	Cylinder 1 1/2" x 10"	2		
13	HH-00972-152	3/4-16 x 3.1/4" Hex Head Cap Screw	2		
13a	53600-0005	3/4" – 16 x 4" Hex Head Cap Screw G8	1		
14	HH-00972-153	3/4-16 x 3.1/2" Hex Head Cap Screw	2		
16	HH-00973-007	3/4-16 Hex Nut Nylon Insert	4		
17	HH-00005-008	3/4-16 Castle Nut	1		
18	HH-00020-087	1/8D x 2L Cotter Pin	1		
19	HH-00540-006	3/4"-16 Nylon insert locknut	1		

Installation Instructions

1. Lay blade face down on the floor. Attach quadrant (11) to blade by inserting rivets (3) through the holes in the quadrant lugs and blade ribs. Install the centre one first. Secure the rivets with the cotter pins.
2. Take an eye bolt (1) and screw one nut all the way down the thread. Attach spring (2) to the quadrant and the eye bolt, making sure the open end of the spring faces up on the quadrant. Lift the quadrant and insert the eye bolt through the hole on the corresponding hole in the spring plate. Secure the eye bolt with another nut. This will hold the quadrant in an upward position, and ease installation of the remaining three springs and eye bolts.
3. Tighten the eye bolt upper nut until the spring coils just break loose from each other. Secure eye bolts in position by tightening the lower nut against the blade spring plate.
4. Lift chain (4) is attached by inserting a ½" bolt (6) through the last link and in the hole in the A-frame lifting bar. Tighten a ½" nut (7) and lock washer (8) firmly from the face side of the lifting bar.

To attach snowplow to vehicle mount, proceed as follows

1. Position the vehicle such that the A-frame lugs and vehicle mount are in vertical alignment.
2. Hook the chain into the lift channel slot.
3. Actuate lift cylinder slowly. Blade will remain on the ground, but the A-frame will begin to rise. Continue until the A-frame lug holes align with the holes on the vehicle mount.
4. Insert the spreader pins (5) through the holes to attach the A-frame to the vehicle mount. Secure attachment by inserting cotter pins (5a) into the spreader pins.
5. With the control switch in the DOWN position, push the lift channel downward as far as possible and adjust the chain so there are two links of slack.
6. Check the cutting edge clearance. Use a combination of spacer washers until ½" clearance between the ground and cutting edge is achieved. Secure shoes by inserting the lynch pins into the shoe.

Shock Absorber Mounting Kit for HD-S, HD-P & XHD-P

SHOCK ABSORBER KIT
FOR ARCTIC HD & HDXL POLY
BLADE 52298-M-GA

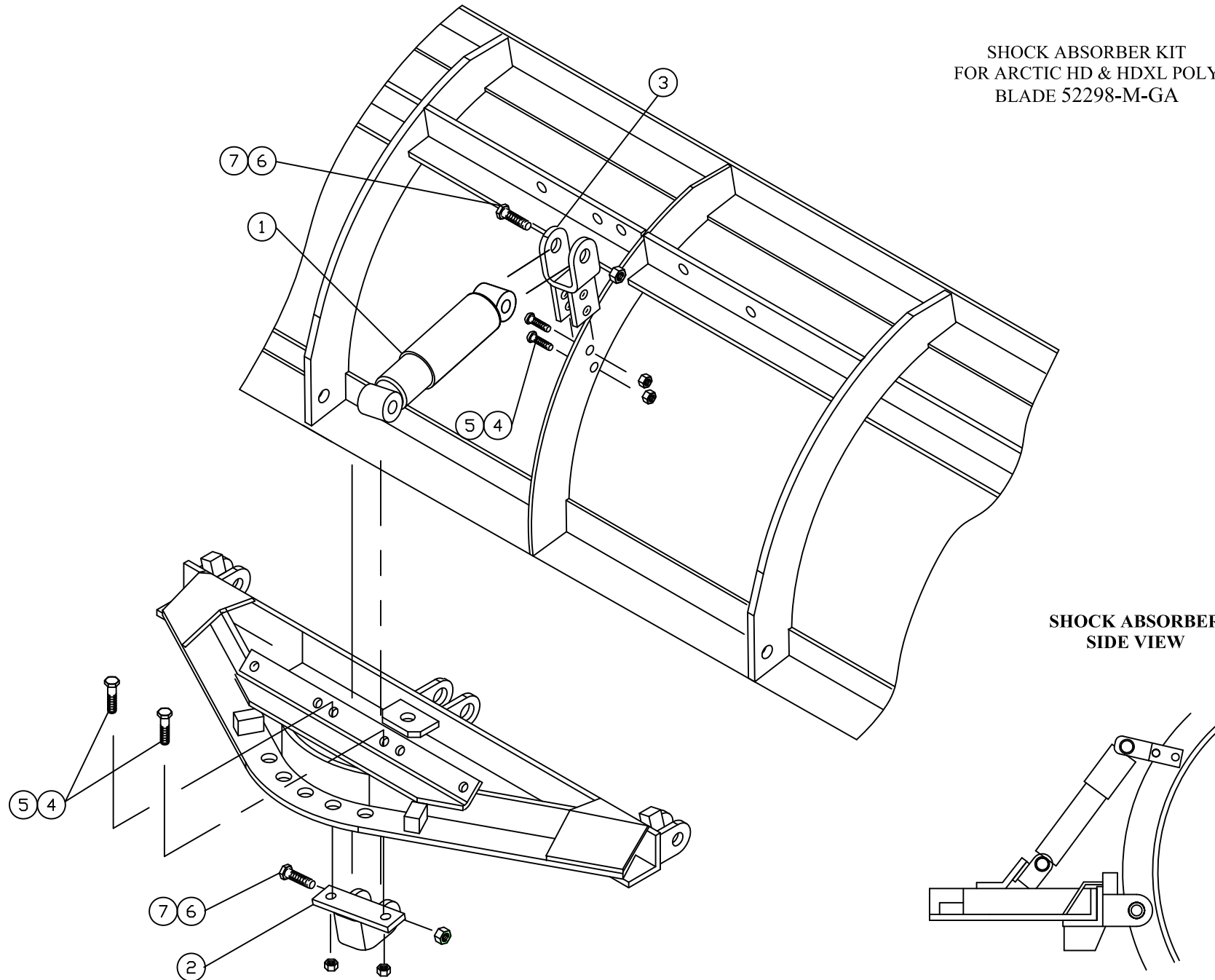

Shock Absorber Mounting Kit 52298-M-GA Galvanized			
Item	Part Number	Description	Quantity
1	51984-M	Shock Absorber	1
2	52285-C-GA	Bottom Shock Bracket	1
3	52287-B-GA	Upper Shock Bracket	1
4	HH-00972-090	1/2-20 x 1 1/2 Hex Head Cap Bolt	4
5	HH-00540-004	1/2" NC Nut Nylon	4
6	HH-00972-152	3/4-16 x 3 1/4" Hex Head Cap Bolt	2
7	HH-00973-007	3/4-16 Nut Nylon	2

Arctic Equipment Manufacturing Corporation reserves the right under its product improvement policy to change construction or design details and furnish equipment when so altered without reference to illustrations or specifications used.

Installation of Pro-Wings (#PW22) on Poly Blade

Warning

Do not exceed the gross vehicle weight ratings (GAWR), front gross axle weight rating (FGAWR) or rear gross axle weight rating (RGAWR) specified on the Safety Compliance Certification Label located in the driver's side door opening.

Brackets kit (used for installation Pro-Wings on Poly Blade) 53287-M			
Item	Part #	Description	Quantity
1	53286-A-GA	Poly Wing Bracket	4
2	53285-A-GA	Poly Wing Plate	2
3	HH-00293-052	3/8-16x1.3/4 HHCS	8
4	HH-00293-050	3/8-16x1.1/4 HHCS	12
5	HH-00294-003	3/8-16 Hex Nut	12
6	HH-00457-004	3/8 Lock washer	12
7	HH-00341-004	3/8 Flat washer	8

Pro-Wings are not included in 53287-M. Pro-Wings are sold separately (part # PW22).

Installation instructions

Caution - Use jack stands to support the blade when installing this kit or when adjusting the shoe height to prevent any injury.



1. Install two Poly Wing Brackets 53286-A-GA as shown on the picture above. Using c-clamp clamp the Poly Wing Brackets 53286-A-GA to the rib of the blade. Using holes in

the Poly Wing Brackets as guide, drill 3/8" holes, 2 of them in the skin and 1 in the rib (3 per bracket). Install the Poly Wing Brackets 53286-A-GA to the rib using 3/8" bolts, lockwashers and nuts.



2. Install Pin Brackets to the Poly Wing Brackets using 3/8" bolts, lockwashers and nuts.



3. Hang the one side of the Pro-Wing on the Pin Bracket. Rotate the Pro-Wing towards the plow's poly moldboard until Pro-Wing's pin is touching the poly skin. Mark with a pencil the location of the center the Pro-Wing Pin. After the Pro-Wing Pin location has been marked remove the Pro-Wing. Drill a pilot hole 1/4" through the poly skin. Hang again Pro-Wing on the Pin Bracket and rotate it towards the plow's poly skin to confirm that 1/4" hole is in the center of the pin hole. If the 1/4" hole is in the center of the pin open 1/4" hole to 1 1/8" hole.
4. Using c-clamp clamp the Poly Wing Plate 53285-A-GA to the blade ribs. (1 1/8" hole in the Poly Wing Plate must line up with 1 1/8" hole already drilled on the poly skin). Using four 7/16" holes in the Poly Wing Plate as guide, drill 3/8" holes (4 holes per side). Install Poly Wing Plate 53285-A-GA using 3/8" bolts, lockwashers and nuts.

5. Place the Pro-Wing on the Pin Bracket and rotate the wing through the plow poly skin hole. Secure the wing to the plow with three of supplied lynch pins.



6. Verify the plow's cutting edge is on the ground. Hold the rubber cutting edge tightly against the ground, the Pro-Wing and plow's cutting edge. Mark location of the two holes in the bottom of the Pro-Wing on the rubber cutting edge from the rear and drill two 5/8 holes. Secure the rubber cutting edge to the Pro-Wing using 1/2" carriage bolt, 5/8" flat washer and nuts.

Arctic Equipment Manufacturing Corporation reserves the right under its product improvement policy to change construction or design details and furnish equipment when so altered without reference to illustrations or specifications used.

Extension Angle for HD-S, HD-P & XHD-P blade

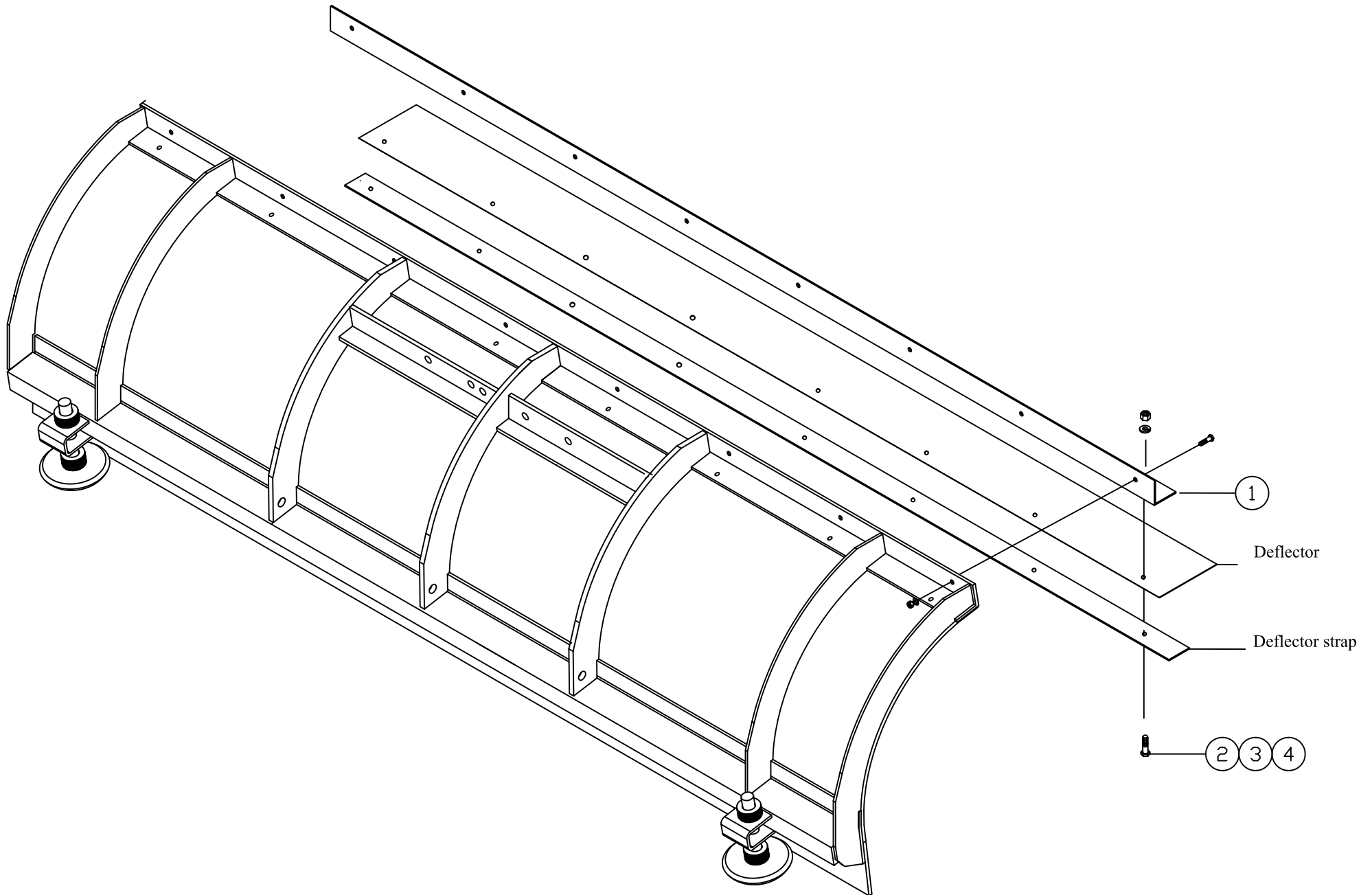

Deflector extension angle (# 53320-03-M 90" HD Poly Blade, # 53320-04-M 96" HD Poly Blade, # 53320-05-M 102" HDXL Poly Blade, # 53321-M 108" HDXL Poly Blade)			
Item	Part #	Description	Quantity
1	53320-03-D-GA	Top Angle 90"	1
	53320-04-D-GA	Top Angle 96"	
	53320-05-D-GA	Top Angle 102"	
	53321-D-GA	Top Angle 108"	
2	HH-00971-044	Carriage Bolt 5/16"	8 (10 for 108" blade)
3	HH-00457-007	Lock washer 5/16"	8 (10 for 108" blade)
4	HH-00294-002	Nut 5/16"	8 (10 for 108" blade)

Warning

Do not exceed the gross vehicle weight ratings (GAWR), front gross axle weight rating (FGAWR) or rear gross axle weight rating (RGAWR) specified on the Safety Compliance Certification Label located in the driver's side door opening.

Arctic Equipment Manufacturing Corporation reserves the right under its product improvement policy to change construction or design details and furnish equipment when so altered without reference to illustrations or specifications used.