

Mounting kit 52895-MKPB-QLIV

F150 4x4 2004 -2008

For the snowplow lights this kit requires:

800084, 800085 or 800086 light kit,

53617-M wiring kit and 800034 Adapter kit (vehicle's headlamp bulb H13)

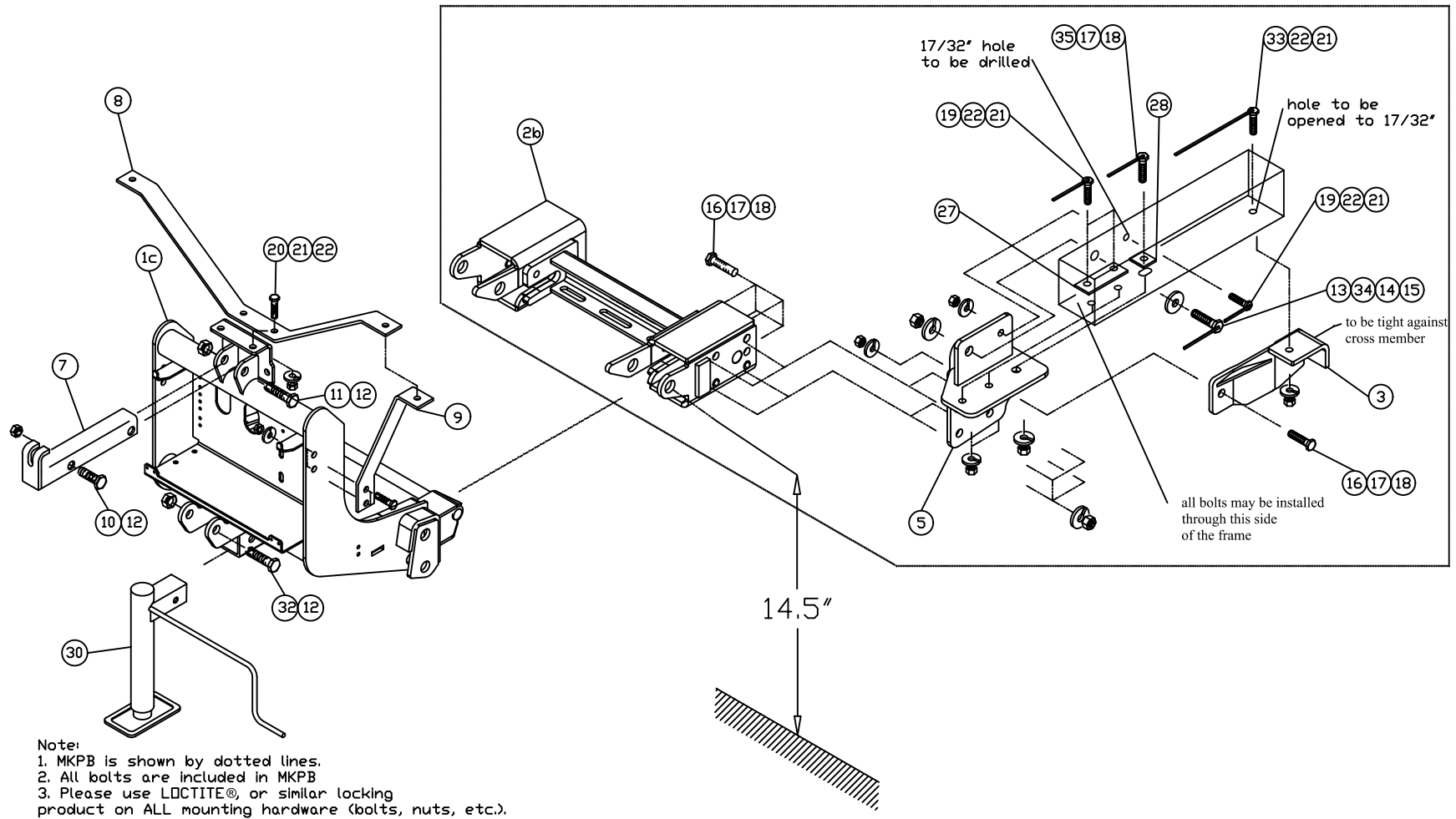

Item	Part #	Description	Quantity
1a*	53170-D-GA	Lift Frame, QUIK*LINK ® II- low mount	1
1b*	53171-D-GA	Lift Frame, QUIK*LINK ® II-Hi boy	1
1c	53564-D	Lift Frame, QUIK*LINK ® IV- low mount	1
2*	52166-C	Spreader Bar	1
2a*	52363-C	Spreader Bar QLII	1
2b	53551-C	Spreader Bar QLIV	1
3	52900-01-B	Thrust Arm, Driver Side	1
4*	52900-02-B	Thrust Arm, Curb Side	1
5	52896-01-D	Mounting Bracket, Driver Side	1
6*	52896-02-D	Mounting Bracket, Curb Side	1
7	50069-C-GA	Lift Channel (1 ½" cylinder)	1
7a*	52612-B-GA	Lift Channel (2" cylinder)	1
8	52209-B-GA	Light Antler	1
9	52208-B-GA	Light Bracer	2
10	HH-00972-149	3/4" x 2½" UNF Cap screw	1
11	HH-00972-153	3/4" x 3½" UNF Cap screw	1
12	HH-00973-007	3/4" UNF Thin Collar Lock nut	3
13	52575-08-A	3/4" bolt with 10" welded handle	2
14	HH-00457-008	3/4 Lock washer	2
15	HH-00460-007	3/4-16 Hex nut	2
16	HH-00972-129	5/8-18x1.3/4 UNF Cap screw	10
17	HH-00457-003	5/8 Lock washer	12
18	HH-00460-001	5/8-18 Hex nut	12
19	52320-A	½" bolt with 10" welded handle	6
20	HH-00972-090	1/2-20x1.1/2 UNF Cap screw	6
21	HH-00460-002	1/2-20 Hex nut	14

Item	Part #	Description	Quantity
22	HH-00457-001	1/2 Lock washer	14
23*	HH-00293-006	1/4" x 1" Cap screw	4
24*	HH-00457-006	1/4" Lock washer	4
26*	HH-00294-001	1/4" Hex nut	4
27	52064-A	Backing Plate	2
28	52908-A	Washer plate	2
29*	WA-34704-M	Mounting Pin, QLI Ass'y	2
29a*	52348-M	Mounting Pin Ass'y	2
30	52373-M	Jack Assembly	1
31*	50999-B	Blade guides	2
32	HH-00972-155	3/4" x 4" UNF Cap screw	1
33	52575-06-A	½" Bolt with 8" welded handle	2
34	HH-00341-009	Flat washer 3/4"	2
35	52575-05-A	5/8" Bolt with 10" welded handle	2
36*	52895-M-WB	52895 Bolt bag c/w welded bolts	-

QUIK*LINK is a trademark of Arctic Equipment Manufacturing Corporation

Note: * These items are not shown on the drawing.

GENERAL INFORMATION

Customer must be aware of following:

Arctic Equipment Manufacturing Corporation (Arctic) does not assume liability for damage to your motor vehicle resulting from the attachment or use of an Arctic snowplow. The purchaser assumes all vehicle risk associated with the attachment and operation of this snowplow.

The Arctic snowplow you purchase must be used only on vehicles equipped with the manufacturer's snow plow preparation package. Snow plowing without the original plow preparation package may damage your vehicle. The added weight may impair the operation and control of your vehicle. Snow plowing with a vehicle not recommended for that purpose by the manufacturer may void your new vehicle warranty. If your vehicle is not equipped with an original snow plow preparation package, additional equipment may be necessary before snow plowing. Please consult your vehicle and snowplow dealers prior to the purchase and installation of the snowplow. The installation of such parts however is not a full substitute for the original equipment snowplow preparation package.

Before drilling any holes in the firewall or frame, move brake lines, fuel lines and/or electrical wiring from the path of the drill. Brake and fuel lines must also be clear of any fasteners.

All bolts should be installed from the inside of the truck frame so that the lock washers and nuts are accessible for re-tightening.

If a slotted hole in the truck frame is utilized, then a flat washer must be used under the bolt head. If a flat washer is used under a lock washer use LOCTITE #242. Also use this LOCTITE #242 if existing (vehicle) bolts and nuts are used.

Do not tighten any bolt assemblies until all fasteners and components are installed, unless otherwise specified.

After first use, re-tighten all mounting bolts, thereafter check mounting bolt tightness periodically.

Before proceeding, read instructions carefully and familiarize yourself with the components and hardware.

INSTALLATION INSTRUCTIONS

1. Remove the lower splash pan from the bumper. The bumper may or may not be removed because all the bolts may be installed through the frame.
2. Remove tow hooks.
3. Do not tighten any hardware until instructed to do so.
4. Install driver side (5) and curb side (6) mounting brackets using ½" bolt (19), lock washer (22) and nut (21) and 5/8" bolt (16), 5/8" lock washer (17) and 5/8" nut (18) (also install backing plate (27) for ½" bolts and washer plate (28) for 5/8" bolt). Note: Two tow hooks could be installed. Be sure that mounting bracket is tight against the bottom of the vehicle frame. Drill 17/32" hole through side of the vehicle frame using 9/16" hole in mounting bracket as a guide. Insert ½" bolt (19) from inside the frame through the mounting brackets (5) and (6). Secure using ½" lock washer (22) and ½" hex nut (21). Install 3/4" bolt (13), 3/4" flat washer (34), 3/4" lock washer (14) and 3/4" nut (15).
5. Install thrust arm(3) (4) to the mounting bracket using 5/8" bolt (16) , 5/8" lock washer (17) and 5/8" nut (18). Ensure that thrust arms are tight against cross member before drilling 17/32" hole, using 9/16"holes in thrust arm as guide (there is already pilot hole in the vehicle frame). Insert ½" welded bolt (33) from inside the frame, down through the thrust arm (3) and (4). Secure using ½" lock washers (22) and ½" hex nuts (21).

6. Insert the spreader bar (2b) between mounting brackets (5) and (6). The spreader pin hole should be located 14 1/2" (+/- 1/2") off of the ground. Insert 5/8" x 2 1/4" bolts (16) from inside spreader bar through mounting bracket holes and secure with 5/8" lock washer (17) and 5/8" nut (18).
7. Reinstall bumper. Do not reinstall splash pan.
8. Torque all fasteners according to torque chart.
9. Install lift frame (1c). Slide inside of spreader bar (2b).
10. Install light antler (8) and light braces (9) using 1/2" x 1 1/2" bolts (20), 1/2" lock washers (22) and 1/2" hex nuts (21). Install lights so that the light mounting stud goes through both antler (8) and the brace (9). Tighten all light mounting hardware.
11. Install lift channel (7) and front mount pump (from hydraulic kit) or hydraulic cylinder to lift frame (1c) using 3/4" x 3 1/2" bolts (11) and 3/4" locknuts (12). Use 3/4" x 2 1/2" bolt (10) and 3/4" locknut (12) to attach lift channel (7) to front mount pump or hydraulic cylinder. Do not over tighten this assembly as it must be able to pivot.
12. Use 1/4"x1" bolt (23), 1/4" flat washer (25), 1/4" lock washer (24) and 1/4" hex nut (26) to fasten blade guides to plow.
13. Return any unused items to the customer so that the vehicle can be returned to its original condition if the snowplow is removed.
14. See separate installation instructions for the hydraulic power unit, wiring and controls.

Torque Chart (Ft. Lb)		
Size	Grade 5 Bolt	Grade 8 Bolt
1/4 - 28	8	11
5/16 - 24	15	22
3/8 - 24	28	40
7/16- 20	44	63
1/2- 20	69	97
5/8- 18	138	195
3/4-16	241	341
Note: Torque values are for plated bolts only.		