

ARCTIC HDFVTE-P

Arctic Heavy Duty Flared 'V' Trip Edge Blade

96" & 108"

 **Warning**

Do not exceed GVWR or GAWR, including blade and ballast. The rating label is found on the driver side vehicle door corners.

Lower the blade when the vehicle is parked. Temperature changes could change hydraulic pressure, causing the blade to drop unexpectedly or damaging hydraulic components. Failure to do this can result in serious personal injury.

Servicing the trip springs without special tools and knowledge could result in personal injury. See Arctic authorized dealer for service.

Inspect snowplow components and bolts for wear and damage when mounting or removing snowplow and before traveling.

Keep hands and feet clear of the blade, A-frame and cylinders when mounting or removing the snowplow. Moving or falling assemblies could cause personal injury. Never use a finger to check an alignment. Moving or falling assemblies could crush your finger.

Do not stand between the vehicle and the blade or within 10' of a moving blade. A moving or falling blade could cause personal injury.

To prevent accidental movement of the blade, always turn the control OFF whenever the snowplow is not in use.

Warning

Do not exceed GVWR or GAWR, including blade and ballast. The rating label is found on the driver side vehicle door corners.

Warning

Lower the blade when the vehicle is parked. Temperature changes could change hydraulic pressure, causing the blade to drop unexpectedly or damaging hydraulic components. Failure to do this can result in serious personal injury.

Warning

Servicing the trip springs without special tools and knowledge could result in personal injury. See Arctic authorized dealer for service.

Warning

Inspect snowplow components for wear and damage when mounting or removing snowplow and before traveling.

Warning

Keep hands and feet clear of the blade, A-frame and cylinders when mounting or removing the snowplow. Moving or falling assemblies could cause personal injury. Never use a finger to check an alignment. Moving or falling assemblies could crush your finger.

Warning

The driver should keep bystanders clear of the blade when it is being raised, lowered or angled. Do not stand between the vehicle and the blade or within 3 meters of a moving blade. A moving or falling blade could cause personal injury.

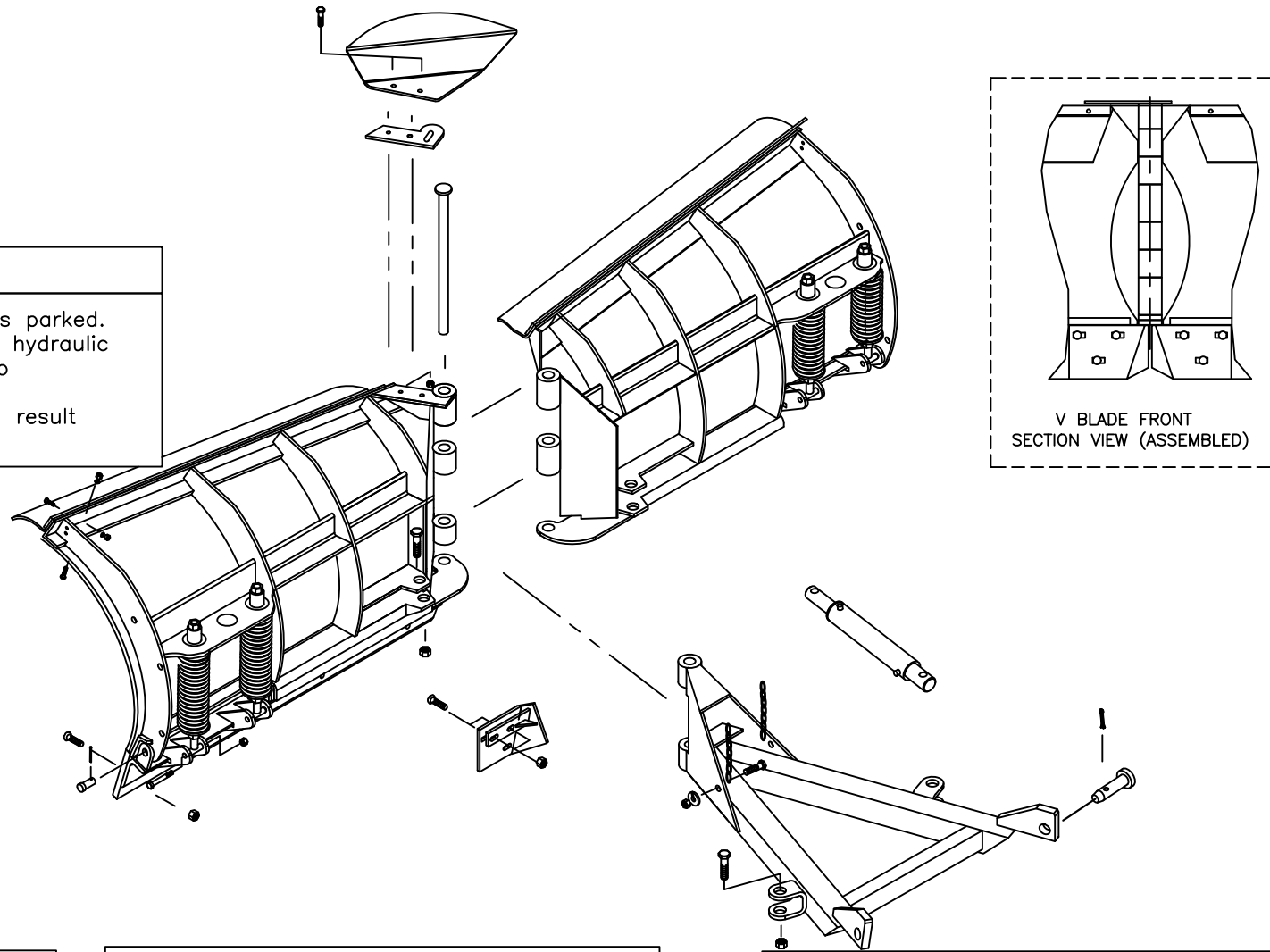

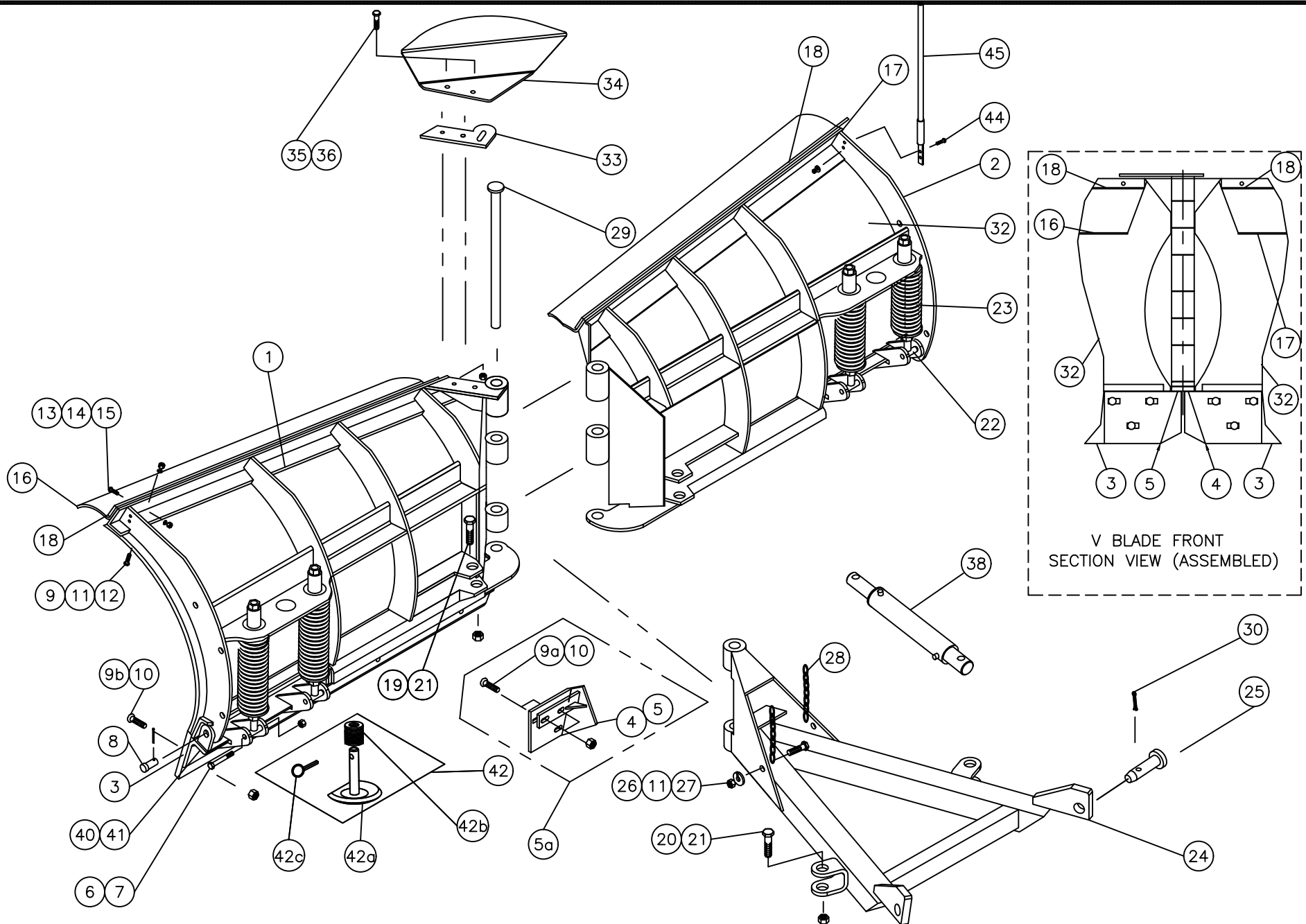

Arctic Heavy Duty Flared 'V' Trip Edge Blade 96" (53719-M), 108" blade (53722-M), A-frame and Hardware			
Item	Description	Part Number	Quantity
1	52720-M	Driver Side Blade Section Assembly (96")	1
	53723-M	Driver Side Blade Section Assembly (108")	1
2	53721-M	Curb Side Blade Section Assembly (96")	1
	53724-M	Curb Side Blade Section Assembly (108")	1
3	53350-B	Steel Cutting Edge (96") Top Punch 1/2" x 6"	2
	53351-B	Steel Cutting Edge (108") Top Punch 1/2" x 6"	2
4	53347-01-B	Centre Cutting Edge Driver Side (Top Punch)	1
5	53347-02-B	Centre Cutting Edge Curb Side (Top Punch)	1
5a	53347-M	Centre Cutting Edge Kit (Top Punch) (includes driver and curb side cutting edge & hardware)	1
6	HH-00540-004	1/2" Nylon Nut	4
7	53015-N	1/2"UNF Bolt 5" long	4
8	52442-M	3/4 x 2-1/8" Rivet c/w Cotter Pin	8
9	HH-00971-136	1/2" x 1-1/2" Carriage Bolt	8
9a	HH-00971-140	1/2" x 2-1/2" Carriage Bolt	4
9b	HH-00971-137G8	1/2" x 1-3/4" Carriage Bolt	12
10	HH-00340-003	1/2" NC Nylon Nut	12
11	HH-00457-001	1/2" Lock Washer	8
12	HH-00294-005	1/2" NC Nut	8
13	HH-00971-044	5/16" x1-1/4"Carriage Bolt	8
14	HH-00457-007	5/16" Lock Washer	8
15	HH-00294-002	5/16" NC Nut	8
16	53747-01-CR	Curved Deflector Driver Side (96" Flared V-blade)	1
	53748-01-CR	Curved Deflector Driver Side (108"Flared V-blade)	1
17	53747-02-CR	Curved Deflector Curb Side (96" Flared V-blade)	1
	53748-02-CR	Curved Deflector Curb Side (108" Flared V-blade)	1
18	53737-B	Strap Driver Side (96" Flared V-blade)	1
	53738-B	Strap Driver Side (108" Flared V-blade)	1
	53742-B	Strap Curb Side (96" Flared V-blade)	1
	53743-B	Strap Curb Side (108" Flared V-blade)	1
19	53546-N	3/4" x 3-1/2" Bolt	2
20	HH-00972-152	3/4" x 3-1/4" Bolt	2
21	HH-00973-007	3/4" Hex Nut Nylon Insert	4
22	52440-C	Spring Tube Assembly (without spring)	4
23	52441-M	Trip Edge Spring	4
24	52854-C-GA	A-Frame	1
25	53325-A	Spreader Pin	2
26	HH-00972-090	1/2" x 1-1/2" Bolt	2

Arctic Heavy Duty Flared 'V' Trip Edge Blade 96" (53719-M), 108" blade (53722-M), A-frame and Hardware			
Item	Description	Part Number	Quantity
25	53325-A	Spreader Pin	2
26	HH-00972-090	½" x 1-1/2" Bolt	2
27	HH-00460-002	½" Nut	2
28	55018-M	Chain	2
29	52860-B	Pivot Pin	1
30	HH-00020-164	Cotter Pin	2
32	53749-D	Flared Poly Blade Skin Driver & Curb Side (96")	1
	53750-D	Flared poly Blade Skin Driver & Curb Side (108")	1
33	53746-B	Top Plate Spacer (Flared V-blade)	2
34	53745-B	Center Deflector (Flared V-blade)	1
35	HH-00293-053	Bolt 3/8" - 16 x 2"	2
36	HH-00340-001	3/8" Nylon Insert	2
38	52873-NRS	Cylinder 1 ½" x 2 1/4" x 9"	2
39	HH-00233-001	1/8" Grease Fitting	6
40	52843-01-D-GA	Base Angle DS (96" V-blade)	1
	52844-01-D-GA	Base Angle DS (108" V-blade)	1
41	52843-02-D-GA	Base Angle CS (96" V-blade)	1
	52844-02-D-GA	Base Angle CS (108" V-blade)	1
42	53322-M	Trip Edge Shoe Assembly	2
42a	53322-A-G	Trip Edge Shoe	1
42b	55017-N	1" Adjustment Washers	15
42c	50040-A	Quick Release Pin	1
44	GB001	Guide Bolt Assembly	4
45	50999-B	Blade Guide	2

Installation Instructions

1. Lay left section of the blade and right section of the blade down on the floor. Align hinges of both sections. Attach A-frame (24) to blade by inserting pivot pin (29) through the hole in the A frame tube and blade cross members. Secure the pivot pin (29) with pin spacer (33) and pin retainer (34) using 3/8" bolt (35), and nut (36).
2. Apply grease at 6 places on the A frame and blade grease fittings. Grease should be reapplied periodically.
3. Secure cylinders (38) with bolts to the blade using 3/4" bolt (19), and 3/4" lock nut (21).

To attach snowplow to vehicle mount, proceed as follows:

1. Position the vehicle such that the A-frame (24) lugs and vehicle mount are in vertical

alignment.

2. Hook the chains (28) into the lift channel slots.
3. Actuate lift cylinder slowly. Blade will remain on the ground, but the A-frame (24) will begin to rise. Continue until the A-frame (24) lug holes align with the holes on the vehicle mount.
4. Insert the spreader pins (25) through the holes to attach the A-frame (24) to the vehicle mount. Secure attachment by inserting cotter pins (30) into the spreader pins (25).
5. With the joystick in the DOWN position, push the lift channel downward as far as possible and adjust the chain so there are two links of slack.
6. Check the cutting-edge clearance. Use a combination of spacer washers until ½" clearance between the ground and cutting edge is achieved. Secure shoes by inserting the lynch pins into the shoe.

Arctic Equipment Manufacturing Corporation reserves the right under its product improvement policy to change construction or design details and furnish equipment when so altered without reference to illustrations or specifications used.

Third Spring Installation Kit 53014-M & Spring Installation Tool 53031-M

Third Spring Installation kit 53014-M			
Item	Part#	Description	Qty
1	54440-C	Spring Tube ass'y	2
2	54441-M	Trip Edge Spring	2
3	53987-M	1/2" x5.5" long rod and nut ass'y	4
4	HH-00341-006	1/2" Flat washer	12
5	HH-00457-001	1/2" Lock washer	4
6	HH-00294-005	1/2" -13 Hex nut	4

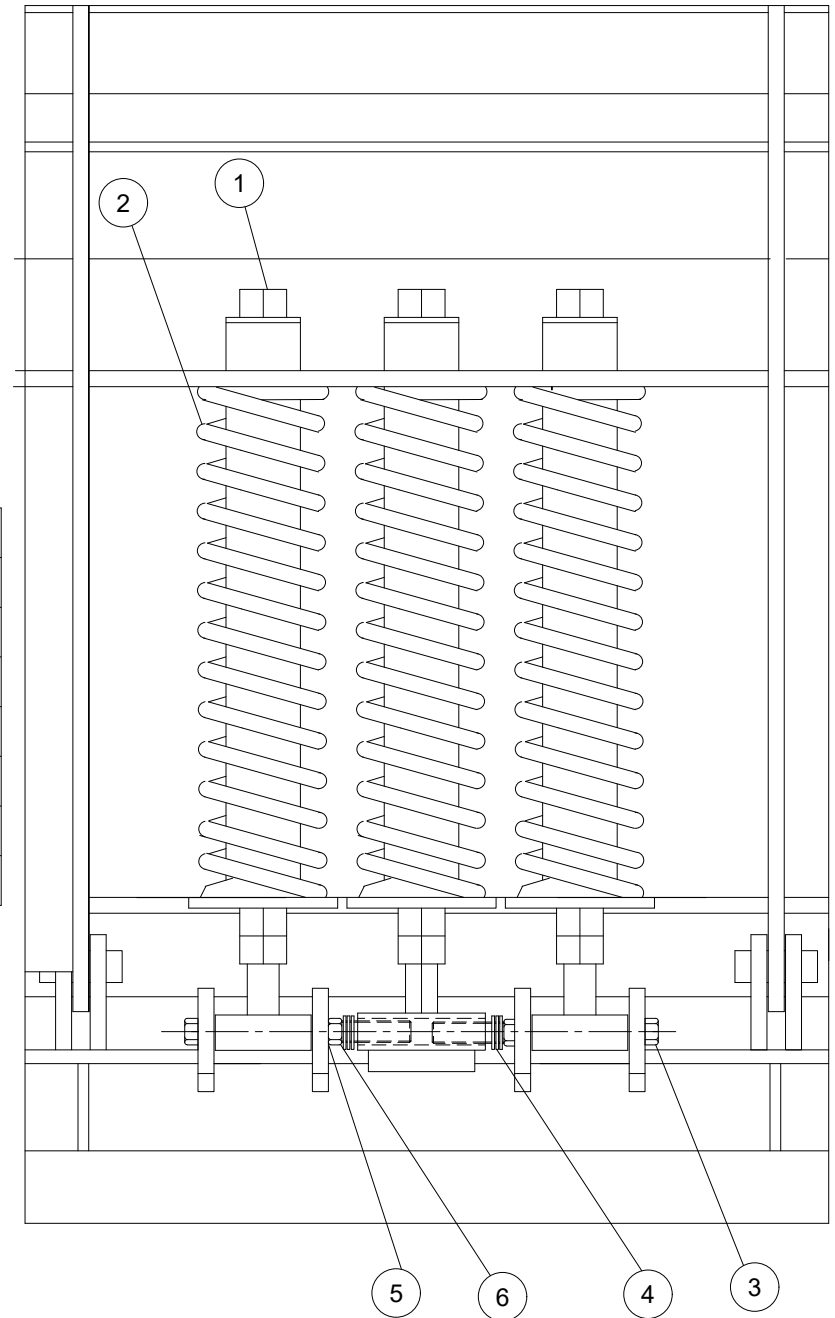

Trip Edge Spring installation tool 53031-M

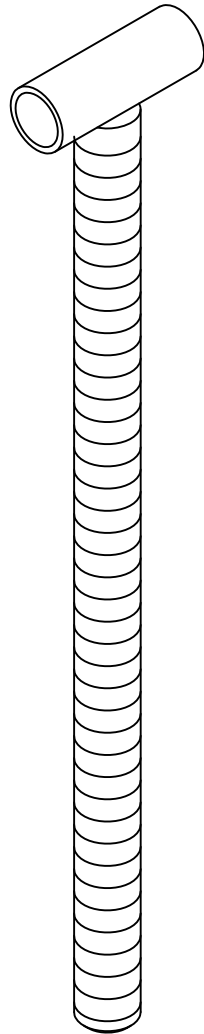

3/4" stud
part # 53034-A

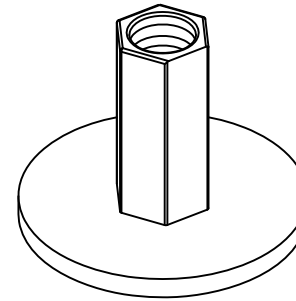

Top Plate (with hex coupling)
part # 53033-A

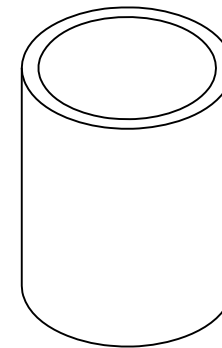

Tube
part # 53032-N

Spring Removal

Warning:

1. Before you start assembling/ disassembling a trip edge spring inspect all parts for physical damage (threads, welds etc.)
Check that there is not any cracks in welds. If you see any signs of damage, a part must be replaced.
2. Never stand in the front of the spring through assembly or disassembly.
Spring is under compression and if released may cause injury or death.

2. Install the top plate on the $\frac{3}{4}$ " stud and screw the $\frac{3}{4}$ " stud into the spring tube minimum 2".

3. Be sure that the top plate is tight against the tube.

4. Slowly turn the hex coupling to release pressure from the spring.

5. Remove the $\frac{1}{2}$ " nut and be sure that all tension is taken by the $\frac{3}{4}$ " stud. If all tension is taken remove the $\frac{1}{2}$ " bolt.

6. Slowly turn the hex coupling to release pressure from the spring. Note: Be sure when you are turning the hex coupling, that the $\frac{3}{4}$ " stud DOES NOT turn.

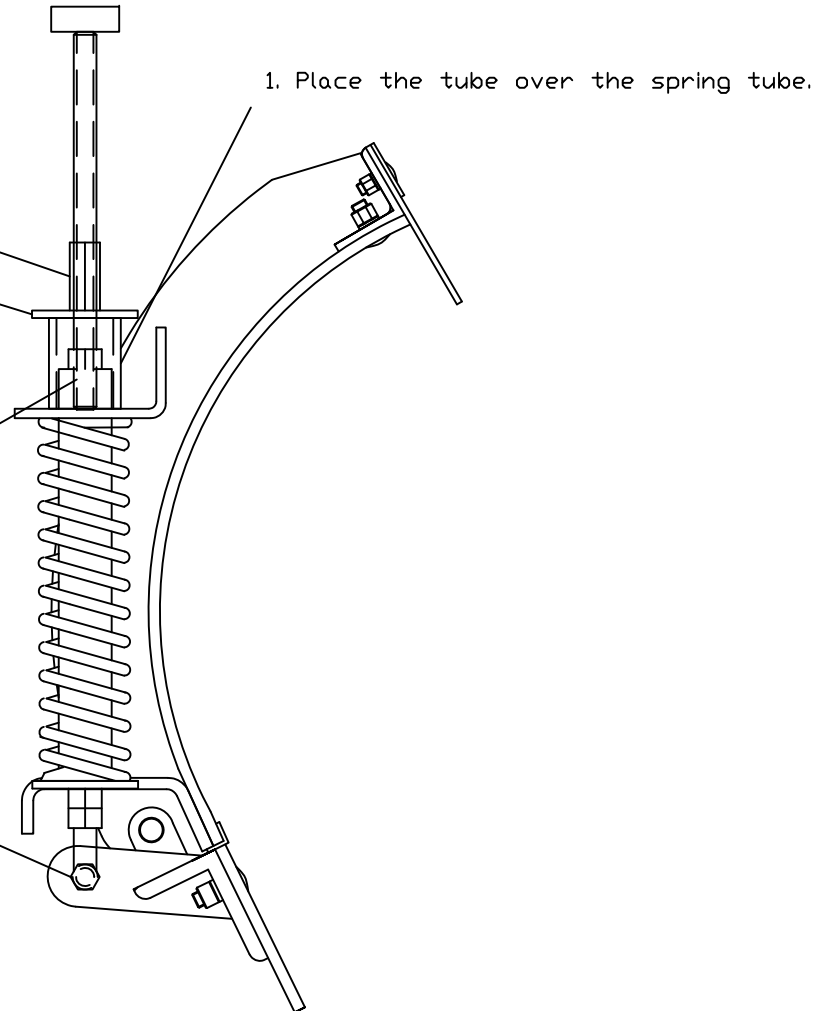

Spring Installation

Warning:

1. Before you start assembling/ disassembling a trip edge spring inspect all parts for physical damage (threads, welds etc.) Check that there is not any cracks in welds. If you see any signs of damage, a part must be replaced.
2. Never stand in the front of the spring through assembly or disassembly. Spring is under compression and if released may cause injury or death.

1. Place the tube over the hole in the spring bracket where the spring tube will go trough.

2. Install the top plate on the $\frac{3}{4}$ " stud and screw the $\frac{3}{4}$ " stud into the spring tube minimum 2".

3. Be sure that the top plate is tight against the tube.

4. Slowly turn the hex coupling to apply pressure to the spring till bottom of the spring tube (the pipe sleeve) is aligned with holes in the lugs (Note: The spring tube is going to be pulled up through the spring bracket). Note: Be sure when you are turning the hex coupling, that the $\frac{3}{4}$ " stud DOES NOT turn.

5. When the pipe sleeve (on the bottom of the spring tube) is aligned with the hole in the lugs, insert the $\frac{1}{2}$ " bolt and secure it with the $\frac{1}{2}$ " nut.

6. When the $\frac{1}{2}$ " bolt is installed the spring installation tool can be removed.

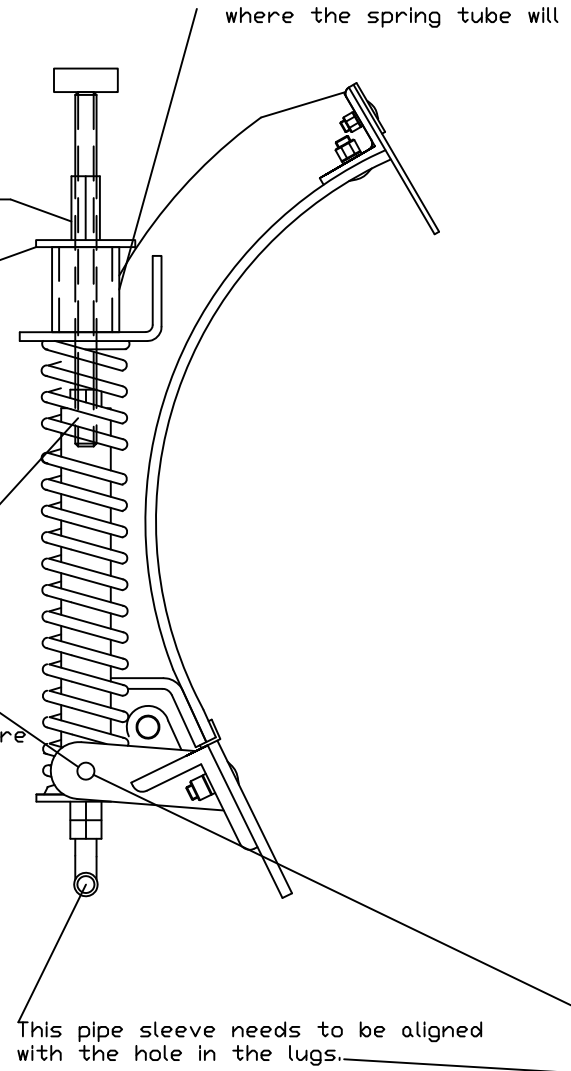

This pipe sleeve needs to be aligned with the hole in the lugs.

Drawing #1

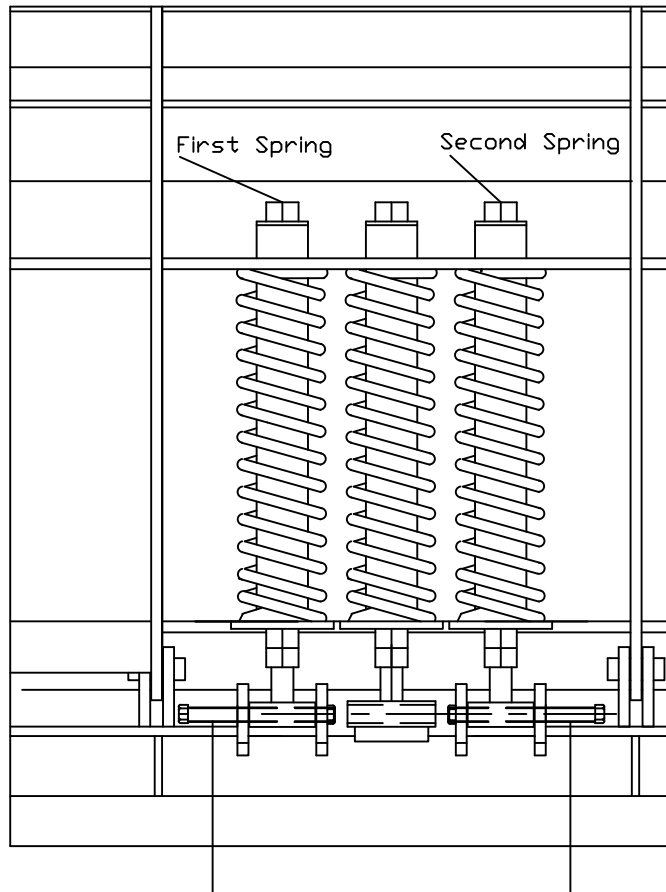

Drawing #2

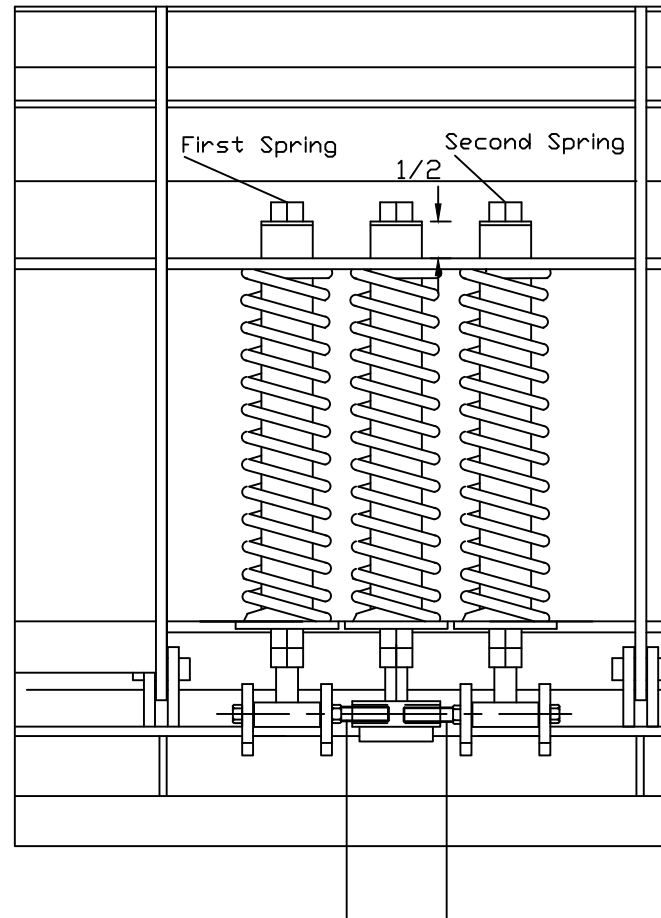

Third Spring Installation

Installation of the third spring:

1. Install the spring installation tool on the first spring as shown on the page 4 and remove existing the $\frac{1}{2}$ " bolt and the nut. Install the $\frac{1}{2}$ " x 5" bolt so that it just passes through the second lug. Install the $\frac{1}{2}$ " lock nut on to the first few threads of the bolt that are past the second lug (see drawing #1).
2. Repeat same procedure with the second spring.
3. Install the third spring as shown on page 5 and screw both $\frac{1}{2}$ " x 5" bolts inside of the spring tube (pipe sleeve drawing #2).