

MOUNTING KIT

52423-MKPB

Bronco 4x4 1980-1986
Bronco 4x4 1987-1991
F150 4x4 1980-1986
F150 4x4 1987-1991
F250 4x4 (Except Diesel) 1980-1986
F250 4x4 (Except Diesel) 1987-1991
F350 SRW 4x4 1980-1986
F350 DRW 4x4 1980-1986
F350 SRW 4x4 1987-1991
F350 DRW 4x4 1987-1991

Note: For the snowplow lights this kit requires: 800067 or 800037AXV Light kit, and Adapter kit:

- For vehicles 1980-1986, Adapter kit is not required

- For vehicles 1987 - up, Adapter Kit 767042 (vehicle's headlamp bulb H9004)

MOUNTING KIT 52423-MKPB-QLII

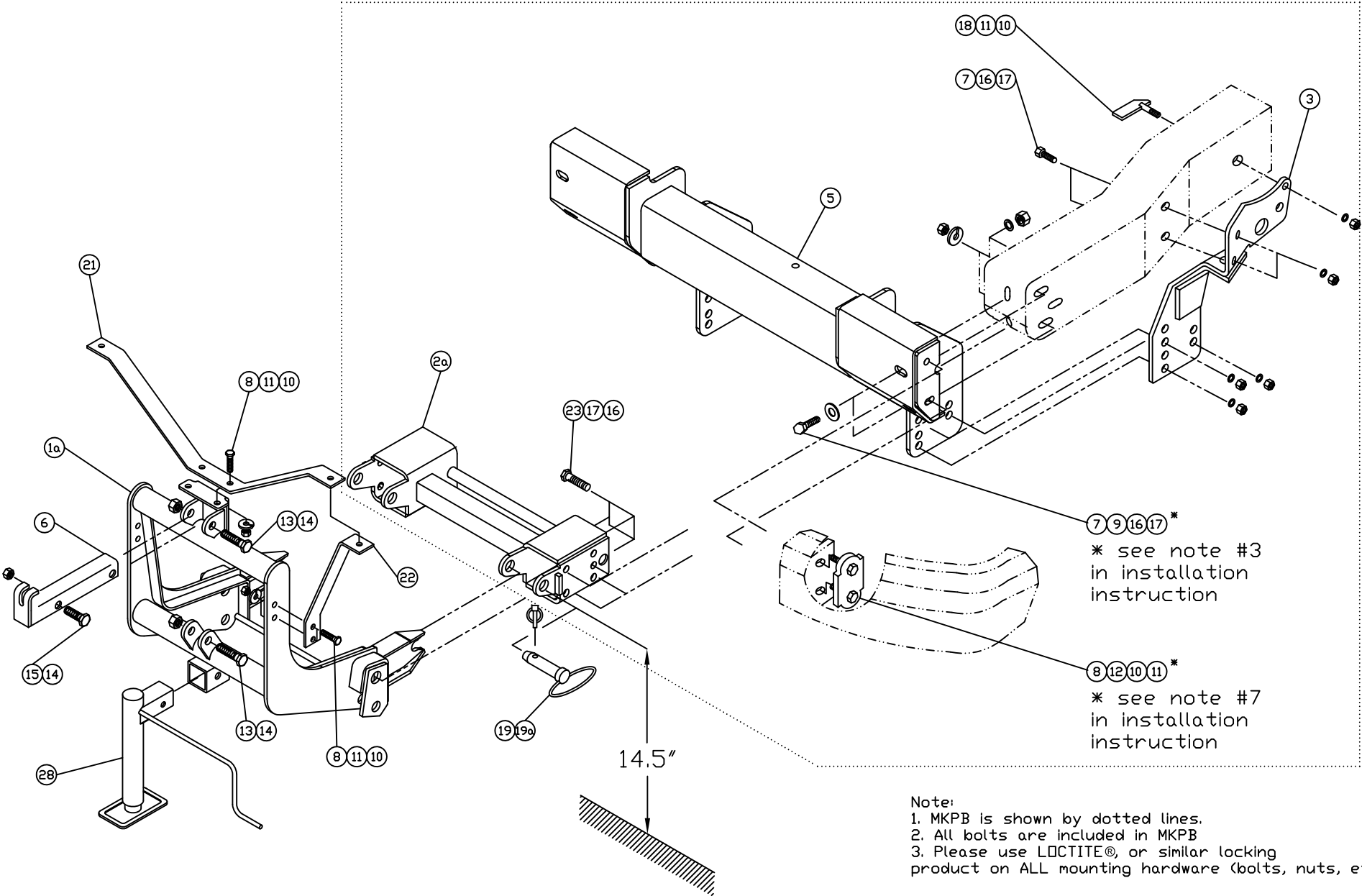

Arctic Equipment Manufacturing Corporation
Mounting kit 52423-MKPB

52423-MKPB R07
INST0030

Mounting Kit 52423-MKPB								
Item	Part #	Description	MKPB	MKPB-QLII	QL-MKB	QLII-MKB	QLII-HI	QLII-HI-DLC
1*	52162-C	Lift Frame			1			
1a	53170-D-GA	Lift Frame, QUIK*LINK ® II Galvanized				1		
1b*	53171-D-GA	Lift Frame, QUIK*LINK ® II-Hi boy Galvanized					1	
2*	52166-C	Spreader Bar	1					
2a	52363-C	Spreader Bar QLII		1				
3	52582-01-D	Thrust Arm Driver Side		1				
4*	52582-02-D	Thrust Arm Curb Side		1				
5	52576-C	Mounting Bracket		1				
6	50069-C-GA	Lift Channel Galvanized				1		
6a*	52612-B-GA	Lift Channel (2" cylinder) Galvanized						1
7	HH-00972-129	5/8"-18 x 1 3/4" Cap screw		8				
8	HH-00972-090	½"x1 1/2" UNF Cap screw		10				
9	HH-00341-008	5/8" Flat washer		4				
10	HH-00460-002	½" UNF Hex Nut		10				
11	HH-00457-001	½" Lock washer		10				
12	HH-00341-006	½" Flat washer		4				
13	HH-00972-153	3/4"x3.1/2" UNF Cap screw		2				
14	HH-00973-007	3/4" UNF Thin Collar Locknut		3				

Arctic Equipment Manufacturing Corporation
Mounting kit 52423-MKPB

52423-MKPB R07
INST0030

Mounting Kit 52423-MKPB								
Item	Part #	Description	MKPB	MKPB-QLII	QL-MKB	QLII-MKB	QLII-HI	QLII-HI-DLC
15	HH-00972-149	3/4"x2.1/2" UNF Cap screw		1				
16	HH-00460-001	5/8" UNF Hex Nut		16				
17	HH-00457-003	5/8" Lock washer		16				
18	52096-A	Thrust arm fastener		2				
19	WA-34704-M	Mounting Pin, QLI, Ass'y			2			
19a	52348-M	Mounting Pin Ass'y					2	
21	52209-B-GA	Light Antler Galvanized				1		
22	52208-B-GA	Light Brace Galvanized				2		
23	HH-00972-131	5/8"x2.1/4" Cap screw		8				
24*	HH-00457-006	1/4" Lock washer		4				
25*	HH-00341-002	1/4" Flat washer		4				
26*	HH-00294-001	1/4" Hex Nut		4				
27*	HH-00293-006	1/4"x1" UNC Cap screw		4				
28	52373-M	Jack Assembly					1	
29*	50999-B	Blade guides				2		
30*	HH-00972-155	3/4" x 4" UNF Cap screw						2

QUIK*LINK is a trademark of Arctic Equipment Manufacturing Corporation

Note: * These items are not shown on the drawing.

GENERAL

Customer must be aware of following:

Arctic Equipment Manufacturing Corporation (Arctic) does not assume liability for damage to your motor vehicle resulting from the attachment or use of an Arctic snowplow. The purchaser assumes all vehicle risk associated with the attachment and operation of this snowplow.

The Arctic snowplow you purchase must be used only on vehicles equipped with the manufacturer's snow plow preparation package. Snow plowing without the original plow preparation package may damage your vehicle. The added weight may impair the operation and control of your vehicle. Snow plowing with a vehicle not recommended for that purpose by the manufacturer may void your new vehicle warranty. If your vehicle is not equipped with an original snow plow preparation package, additional equipment may be necessary before snow plowing. Please consult your vehicle and snowplow dealers prior to the purchase and installation of the snowplow. The installation of such parts however is not a full substitute for the original equipment snowplow preparation package.

Before drilling any holes in the firewall or frame, move brake lines, fuel lines and/or electrical wiring from the path of the drill. Brake and fuel lines must also be clear of any fasteners.

All bolts should be installed from the inside of the truck frame so that the lock washers and nuts are accessible for re tightening.

If a slotted hole in the truck frame is utilized, then a flat washer must be used under the bolt head. If a flat washer must be used under a lock washer use LOCTITE #242. Also use this LOCTITE #242 if existing (vehicle) bolts and nuts are used.

General order of installation:

- install all components (mounting bracket, thrust arm and spreader bar) and all fasteners finger tight (snug) through existing holes,
- drill necessary holes and
- tighten all hardware.

After first use, re tighten all mounting bolts, thereafter check mounting bolt tightness periodically.



Before proceeding, read instructions carefully and familiarize yourself with the components and hardware.

INSTALLATION INSTRUCTIONS

1. Remove the bumper.
2. Install thrust arms (3), (4). Insert thrust arm fasteners (18) into available slots on the truck frame. Fasten the thrust arm (3), (4) with ½" hex nut (10) and ½" lock washer (11). DO NOT TIGHTEN.
3. Install mounting bracket (5).
 - a) If bumper has side mounting bracket:
Insert 5/8"x1 3/4" bolts (7) and flat washers (9) through the bumper front holes in the frame and fasten with nuts (16) and lock washer (17).
 - b) If bumper does not have side mounting bracket:
Insert the original bumper mounting hardware (bolts that bumper is secured to frame) through the bumper front holes in the frame.
4. Install spreader bar (2a), between the thrust arms (3), (4). Fasten using 5/8" x 2 1/4" bolt (26), 5/8" hex nut (16) and 5/8" lock washer (17). The spreader pin hole should be located 14-1/2" (+/- ½") off of the ground. DO NOT TIGHTEN.
5. Push up on the thrust arms (3), (4) so that they are tight against the bottom of the truck frame.
6. Locate and drill two 21/32" holes on each side of the frame using the thrust arm holes (3), (4) as guides.
NOTE: Some models may have a second set of slots in this location. Feed 5/8"x1 3/4" bolts (7) in through the frame using wire and fasten with 5/8" hex nut (16) and lockwasher (17).
7.
 - a) If bumper has side mounting bracket:
Remove top bolt that connects bumper bracket and frame bracket, and weld these two brackets together. NOTE: Fit bumper to brackets for welding.
Adjust the bumper mounted brackets outwards 3/8" per side and install the bumper using the original bumper mounting hardware. Locate the bumper at the same height as originally installed.
 - b) If bumper does not have side mounting bracket:
Use 17/32" drill to drill holes on the side of the frame using holes on the side in mounting bracket as guide. Install ½" x 1 1/2" bolt (8), flat washer (12) and fasten with ½" bolt (10) and lock washer (11). Remove front mounting bolts (see note #3), locate the bumper at the same height as originally installed and install mounting hardware through bumper, mounting bracket and

frame.

8. Tighten all hardware.
9. Install lift frame (1a), (1b). Slide inside of spreader bar (2a). Insert mounting pin (19a) in top holes of spreader bar (2a).
10. Install light antler (21) and light brace (22) using 1/2"x1 1/2" bolts (8), 1/2" hex nut (10) and 1/2" lock washer (11). Fasten light antler (21) to top of the lift frame (1) and light brace (22) to side of lift frame (1). Install plow lamps, not shown, so that stud of plow lamps is through light antler (21) and light brace (20).
11. Torque all fasteners according to torque chart.
12. Install lift channel (6) and lift cylinder (or power unit) to lift frame. Use 3/4"x3.1/2" bolts (13) and 3/4" thin collar locknut (14) at lift frame (1) connection. Use 3/4"x2.1/2" bolt (15) and 3/4" thin collar locknut (14) at cylinder and lift channel (6) connection.
 NOTE: Do not tighten, as this assembly must be able to pivot.
13. Use 1/4"x1" bolt (27), 1/4" hex nut (26), 1/4" flat washer (25) and 1/4" lock washer (24) to fasten blade guides to plow.

TORQUE CHART (FT. LB.)		
SIZE	GRADE 5 BOLT 	GRADE 8 BOLT 
1/4 - 28	8	11
5/16 - 24	15	22
3/8 - 24	28	40
7/16 - 20	44	63
1/2 - 20	69	97
5/8 - 18	138	195
3/4 - 16	241	341
Note: Torque values are for plated bolts only		