

# Mounting Kit 53598-MKPB-QLII

W2500 RAM 4x4 (Except Sport) 2013-2017

W3500 RAM DRW 4x4 (Except Sport) 2013-2017

For installations see YouTube link:

<https://www.youtube.com/watch?v=EK4sY3UyuKE>

or Search on YouTube

[Arctic Snowplows 53598 Mounting Kit](#)

**Ground Clearance Note:** Diesel models, as received from the manufacturer, have an intercooler very low, therefore it does not allow the spreader bar to be installed in the highest holes (the spreader pin hole should be located 14 1/2" (+/- 1/2") of the ground). Suspension modifications may be required in order to achieve sufficient ground clearance to install a snowplow.

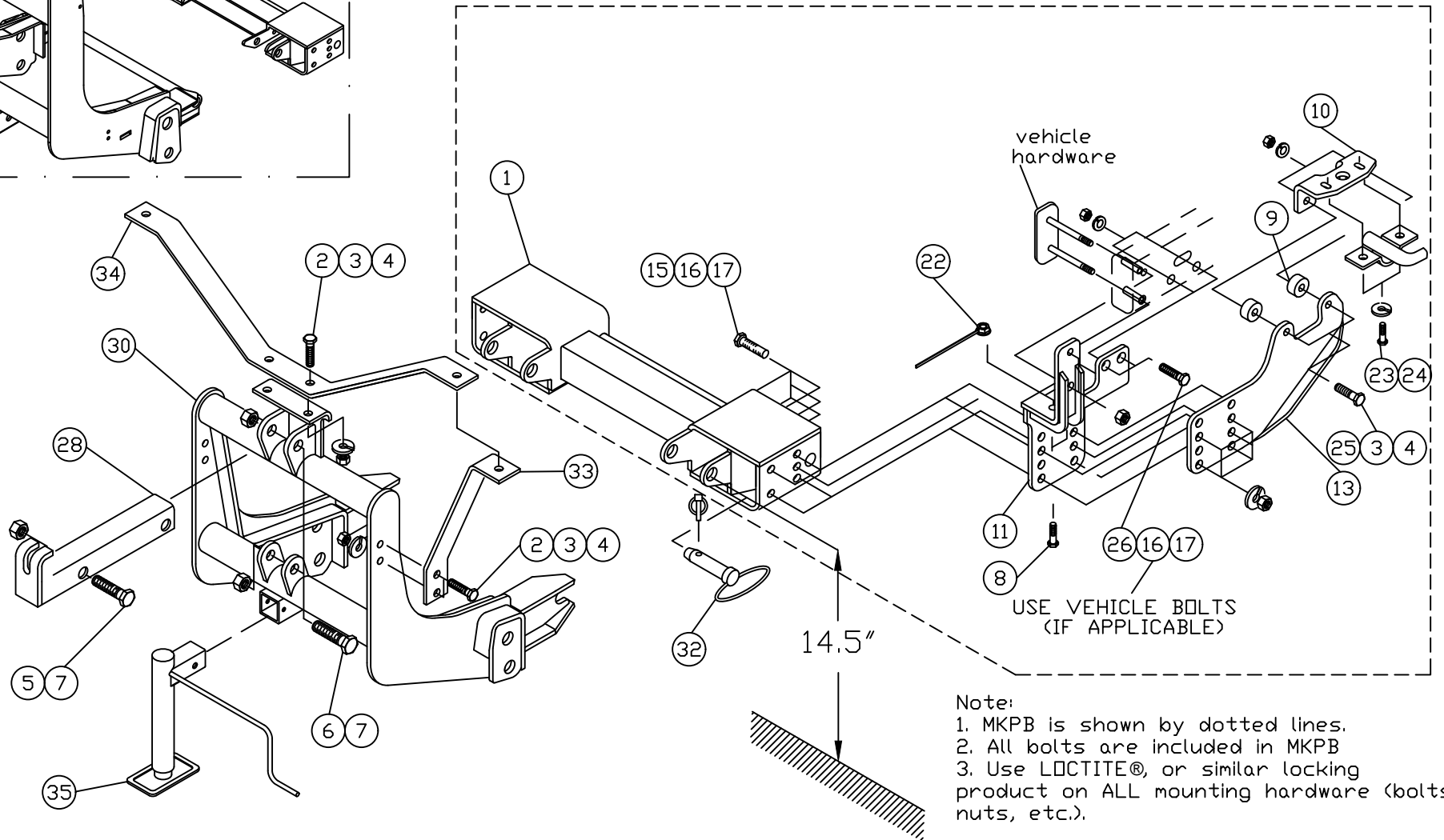
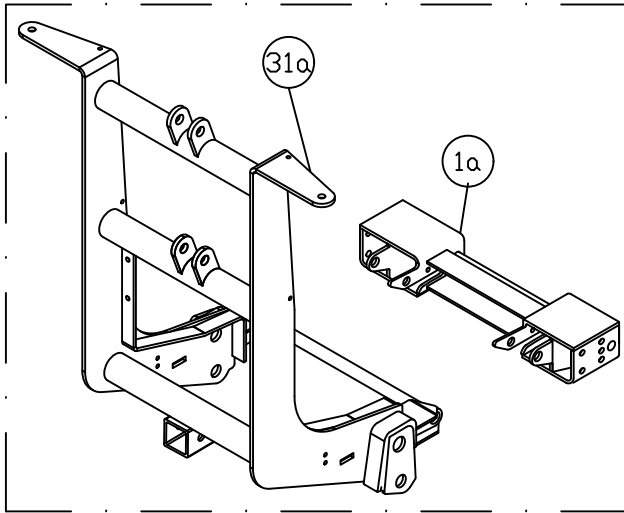

Note:  
 1. MKPB is shown by dotted lines.  
 2. All bolts are included in MKPB  
 3. Use LOCTITE®, or similar locking product on ALL mounting hardware (bolts, nuts, etc.).

| 53598-MKPB-QLII |              |   |          |
|-----------------|--------------|---|----------|
| Item            | Part number  | Description                             | Quantity |
| 1               | 52364-C      | Spreader Bar QLII                       | 1        |
| 1a              | 53507-C      | Spreader Bar QLIV                       | 1        |
| 2               | HH-00972-090 | ½" x 1 ½" UNF Hex Head Cap screw        | 6        |
| 3               | HH-00457-001 | ½" Lock washer                          | 10       |
| 4               | HH-00460-002 | ½" UNF Nut                              | 10       |
| 5               | HH-00972-149 | ¾" x 2 ½" UNF Hex Head Cap screw        | 1        |
| 6               | HH-00972-153 | ¾" x 3 ½" UNF Hex Head Cap screw        | 2        |
| 7               | HH-00973-007 | ¾" UNF Thin Collar Lock nut             | 3        |
| 8               | HH-00293-091 | ½" X 1 ¾" UNC Bolt                      | 4        |
| 9               | 53605-M      | ¾" Spacer                               | 4        |
| 10              | 53606-M      | Top Bracket                             | 2        |
| 11              | 53599-01-C   | Mounting Bracket, Driver Side           | 1        |
| 12              | 53599-02-C   | Mounting Bracket, Curb Side             | 1        |
| 13              | 53601-01-B   | Thrust Arm, Driver Side                 | 1        |
| 14              | 53601-02-B   | Thrust Arm, Curb Side                   | 1        |
| 15              | HH-00972-131 | 5/8" x 2 1/4" UNF Hex Head Cap screw    | 10       |
| 16              | HH-00457-003 | 5/8" Lock washer                        | 14       |
| 17              | HH-00460-001 | 5/8" Hex Nut                            | 14       |
| 18              | HH-00293-006 | 1/4"x1" UNC Hex Head Cap screw          | 4        |
| 19              | HH-00341-002 | 1/4" Flat washer                        | 4        |
| 20              | HH-00457-006 | 1/4" Lockwasher                         | 4        |
| 21              | HH-00294-001 | 1/4" Hex Nut                            | 4        |
| 22              | 52575-14-A   | ½" NC Flanged Nut with welded handle    | 4        |
| 23              | 55600-0003   | 10M x 45mm Bolt                         | 4        |
| 24              | HH-00933-003 | 10 mm Lockwasher                        | 4        |
| 25              | HH-00972-93  | ½" x 2.25" HHCS                         | 4        |
| 26              | HH-00972-133 | 5/8" x 3 3/4" UNF Hex Head Cap screw    | 4        |
| 28*             | 50069-C-GA   | Lift Channel                            | 1        |
| 29*             | 52612-B-GA   | Lift Channel (2" cylinder)              | 1        |
| 30*             | 53170-D-GA   | Lift Frame, QUIK*LINK® II, low mount    | 1        |
| 30a*            | 53564-D      | Lift Frame, QUIK*LINK® IV, low mount    | 1        |
| 31*             | 53171-D-GA   | Lift Frame, QUIK*LINK® II-Hi boy        | 1        |
| 31a*            | 52517-D      | Lift Frame, QUIK*LINK® IV-HI Galvanized | 1        |
| 32*             | 52348-M      | Mounting Pin, Ass'y                     | 2        |
| 33*             | 52208-B-GA   | Light Brace                             | 2        |
| 34*             | 52209-B-GA   | Light Antler                            | 1        |
| 35*             | 52373-M      | Jack Assembly                           | 1        |

\* Parts are not part of 53598-MKPB-QLII

**⚠ Warning**

Arctic Equipment Manufacturing Corporation (Arctic) does not assume liability for damage to your motor vehicle resulting from the attachment or use of an Arctic snowplow. The purchaser assumes all vehicle risk associated with the attachment and operation of this snowplow.

The Arctic snowplow you purchase must be used only on vehicles equipped with the manufacturer's snow plow preparation packages. Snow plowing without the original plow preparation package may damage your vehicle. The added weight may impair the operation and control of your vehicle. Snow plowing with a vehicle not recommended for that purpose by the manufacturer may void your new vehicle warranty. If your vehicle is not equipped with an original snow plow preparation package, additional equipment may be necessary before snow plowing. Please consult your vehicle and snowplow dealers prior to the purchase and installation of the snowplow. The installation of such parts however is not a full substitute for the original equipment snowplow preparation package.

The loaded vehicle, including all aftermarket accessories, the snowplow, passengers and cargo, must not exceed the gross vehicle weight ratings (GAWR), front gross axle weight rating (FGAWR) or rear gross axle weight rating (RGAWR) specified on the Safety Compliance Certification Label located in the driver's side door opening. It is the operator's responsibility to verify that these rating are not exceeded. The use of rear ballast weight may be required to prevent exceeding the front GAWR.

To determine the Gross Axle Weights for your vehicle, including all aftermarket accessories, the snowplow, passengers and cargo, take your loaded vehicle and the snowplow to a scale. With the snowplow attached, place the front wheels of the vehicle on the scale to get the front gross axle weight (FGAW). To get the rear gross axle weight (RGAW), place the back wheels of the vehicle on the scale.

## Installation Instructions

Before drilling any holes in the firewall or frame, move brake lines, fuel lines and/or electrical wiring from the path of the drill. Brake and fuel lines must also be clear of any fasteners. Do not under any circumstances disable, remove or relocate any sensors or other components related to the operation of the air bags.

General order of installation:

- install all components (mounting bracket, thrust arm and spreader bar) and all fasteners finger tight (snug) through existing holes,
- use removable grade LOCTITE #242 on all bolts,
- drill necessary holes and
- tighten all hardware.

After first use, retighten all mounting bolts, thereafter check mounting bolt tightness periodically and at the start of the season.

Before proceeding, read instructions carefully and familiarize yourself with the components and hardware.

NOTE: It may be necessary, on some vehicles, to use a form of load booster to decrease the vehicle's front suspension sag when snowplows is attached to the vehicle. This can be done with the use of, booster springs, supplementary air bags or similar load boosting devices. It is up to the customer to choose and purchase the product that suits this application.

Arctic Equipment Manufacturing reserves the right, under its product improvement policy, to change construction, design details or specifications without notice or without incurring any obligation

### 1. Remove the bumper.

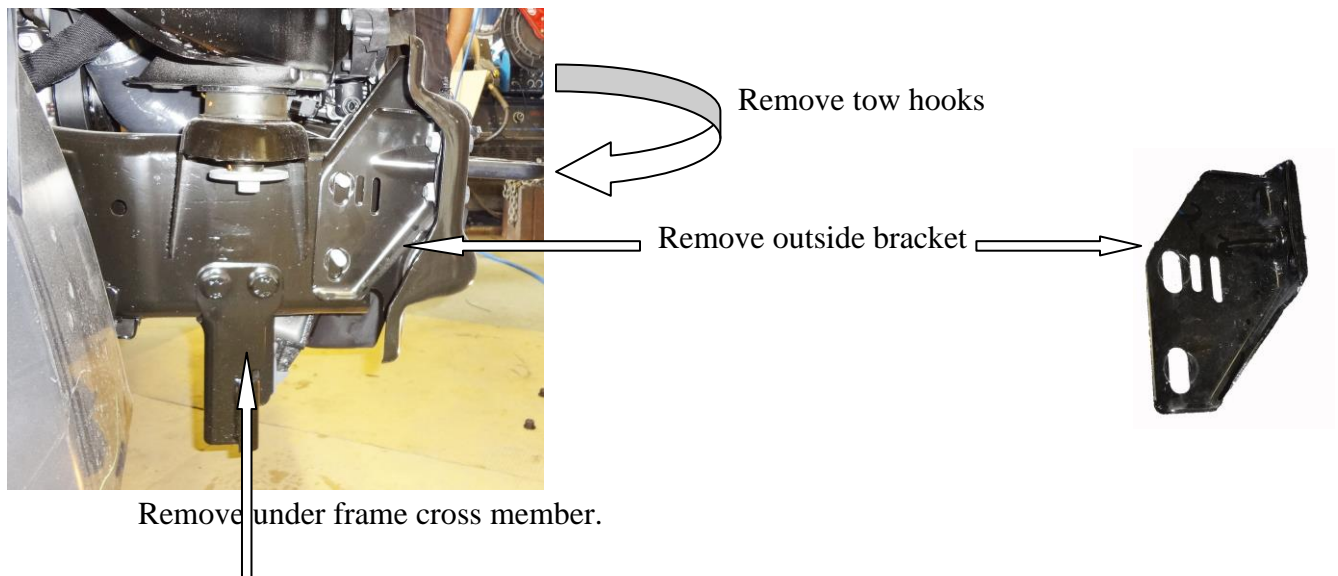

2. Remove tow hooks and outer tow hook bracket. These parts will not be used; they should be returned to customer together with fasteners.
3. Remove also the under frame cross member and it should be returned to the customer. Bolts and nuts can be reinstalled to secure the mounting bracket (11).
4. Lower the stabilizer bar by removing two bolts located on the bottom of the vehicle frame. Sandwich bracket (10) between the vehicle frame and a stabilizer bracket. Do not use vehicle bolts; use bolts provided in the bolt bag. Install M10 bolts and lock washers (23)(24). Tighten the bolts by pushing bracket as far as possible toward outside of truck.



4. Remove the nuts from the bolts that hold bumper bracket. Slide mounting bracket (11) to the vehicle frame. Insert bumper vehicle bolts through front mounting plate holes and secure with existing vehicle nuts. Insert vehicle bolts and nuts (taken from under frame cross member) through back holes on mounting bracket (11). If there is no under frame cross member use 5/8" bolts, and secure it with nuts and lock washers (26)(16)(17).
7. Install thrust arms (13)(14) and spacers (9), and secure them with 1/2" bolts, nuts and lock washers (25)(3)(4) to the top bracket.



8. Fasten the spreader bar (1) and the thrust arms (13)(14) to mounting brackets (11)(12) using 5/8" x 2 1/4" bolt (15), 5/8" lockwasher (16) and 5/8" hex nut (17). The spreader pin hole should be located 14 1/2" (+/- 1/2") of the ground.

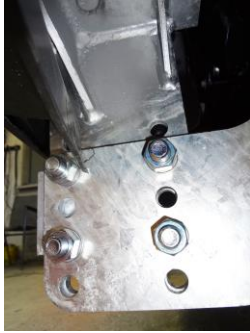

5. Using two front 9/16" holes on the bottom of mounting bracket (11) as guide drill 17/32" holes through the bottom of the vehicle frame (Before drilling Front bumper bolts must be tight before drilling holes through the bottom of the mounting bracket and spreaderbar must be jacked up against the vehicle frame). Insert 1/2" nut with welded handle (22) through the front of the vehicle frame. Bend a handle as shown on the pictures below. Insert 1/2" bolts (8) through the bottom of the vehicle frame and install the 1/2" nuts with welded handle. Do not tighten the bolts. Loosen all bolts that were tightened, before drilling.

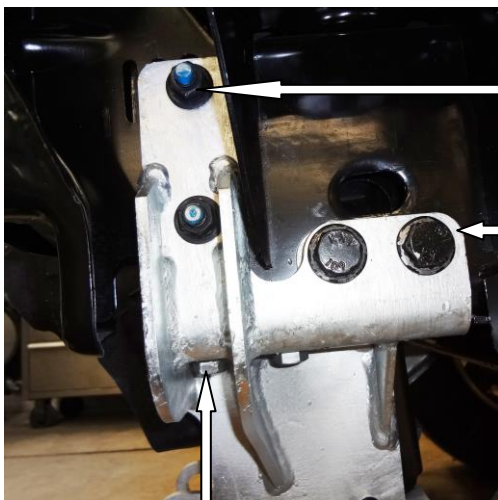

-Existing vehicle hardware (bolts, nuts)

-Existing vehicle hardware  
(or use 5/8" x 2 3/4"(26))

-1/2" x 1 3/4" bolts (8) (apply removable grade LOCTITE #242)



-Bend Curb Side handle



-Bend Driver Side handle

-Driver Side Frame

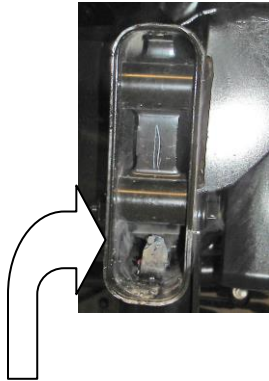

-Install Flanged nuts (22) from this side (inside opening)

6. Torque all fasteners using torque chart. Reinstall bumper as high as possible. Install lift frame (30) (31). Slide inside of spreader bar (1). Insert mounting pin (32) in top holes of spreader bar (1). Note: If a spreader bar is mounted to the top mounting holes, use also one more 5/8" bolt in the middle on both sides.

9. Fasten the light antler (34) to the top of the lift frame (30) using 1/2"x1 1/2" bolt (2), lock washer (3), 1/2" nut (4). Do not tighten hardware. Fasten the light brace (33) to the both sides of the lift frame (34), using 1/2"x1 1/2" bolt (2), lock washer (3), 1/2" nut (4). Do not tighten. Install plow lamps so that the stud is through the light antler (34) and light brace (33).

10. Torque all fasteners according to torque chart.

11. Fasten lift channel (28) and lift cylinder to the lift frame (30) using 3/4"x3 1/2" bolts (6) and 3/4" locknut (7). Use 3/4"x 2 1/2" bolt (5) and 3/4" locknut (7) to attach lift cylinder to lift channel (28). NOTE: Do not over tighten as this assembly must be able to pivot. Use 1/4"x1" bolt (18), 1/4" flat washer (19), 1/4" lock washer (20) and 1/4" hex nut (21) to fasten blade guides to plow.

12. Return any unused items to the customer so that the vehicle can be returned to its original condition if the snowplow is removed.

13. See separate installation instructions for the hydraulic power unit, wiring and controls.

14. Notch the front bumper plastic as shown on the picture to provide clearance when attaching the plow to the truck. Remove only the least amount of material required for clearance to preserve the appearance of the truck.







| Suggested torque value for bolts |              |               |              |               |
|----------------------------------|--------------|---------------|--------------|---------------|
| Thread Size                      | Grade 5      |               | Grade 8      |               |
|                                  | Dry (ft. lb) | Oiled (ft.lb) | Dry (ft. lb) | Oiled (ft.lb) |
| ¼-20                             | 8            | 6             | 12           | 9             |
| ¼-28                             | 10           | 7             | 14           | 11            |
| 5/16-18                          | 17           | 13            | 24           | 18            |
| 5/16-24                          | 19           | 15            | 27           | 21            |
| 3/8-16                           | 31           | 24            | 44           | 34            |
| 3/8-24                           | 35           | 27            | 49           | 38            |
| 7/16-14                          | 49           | 38            | 70           | 54            |
| 7/16-20                          | 55           | 42            | 78           | 60            |
| ½-13                             | 75           | 58            | 105          | 82            |
| ½-20                             | 85           | 65            | 120          | 90            |
| 5/8-11                           | 150          | 115           | 210          | 165           |
| 5/8-18                           | 170          | 130           | 240          | 185           |
| ¾-10                             | 270          | 205           | 375          | 290           |
| ¾-16                             | 295          | 230           | 420          | 320           |
| 7/8-9                            | 395          | 305           | 605          | 455           |
| 7/8-14                           | 435          | 335           | 670          | 515           |
| 1-8                              | 590          | 455           | 905          | 695           |
| 1-14                             | 660          | 510           | 1030         | 785           |

Arctic Equipment Manufacturing Corporation reserves the right under its product improvement policy to change construction or design details and furnish equipment when so altered without reference to illustrations or specifications used herein.