

Arctic Equipment Manufacturing Corporation

Arctic XHD-S

Table of Contents

Arctic Extra Heavy Duty Steel Blade 120" (Blade, Quadrant & A-frame).....2
Arctic Extra Heavy Duty Steel Blade 120" Quadrant & A-frame installation.....5

ARCTIC XHD-S
Arctic Extra Heavy Duty Steel Blade 120"
(Blade, Quadrant, A-frame)

Arctic Extra Heavy Duty Steel 120" Blade (Blade, Quadrant & A frame)			
Item	Description	Part Number	Quantity
1	10' Blade	51127-A	1
2,3	Eye bolt Assembly	50191-M	6
4	Trip Spring	50180-C	6
5	Quick Release Pin	50040-A	4
6	Shoe Washer	55017-N	40
7	5/8" x 2" Carriage bolt	HH-00971-196	11
9	5/8" Lock nut with nylon insert	HH-00340-005	11
10	Heavy Duty Shoe	51028-M	2
11	1/4"x1½" Cotter Pin	HH-00020-164	2
12	1"x3½" Cap screw	HH-00972-187	2
13	1"x4½" Cap screw	HH-00972-190	2
14	1" Lock washer	HH-00457-009	4
15	1" Hex nut	HH-00460-010	4
16	Quadrant	51125-D	1
17,18	1" Locknut	HH-00540-009	3
19	1"x3" Cap screw	HH-00972-185	1
20	Spreader Pin	50853-A	2
21	Blade Pivot Bar	51169-A	1
22	Lift Chain - 36"	55018-M	2
23	½"x1½" Cap screw	HH-00972-090	2
24	½" Lock washer	HH-00457-001	2
25	½" Hex nut	HH-00460-002	2
26	A-Frame	51123-D	1
27,28	Toggle Pin (Optional)	50188-A	2
29	120" Cutting Edge	51162-N	1
30	½"x5" Cap screw	HH-00972-191	2

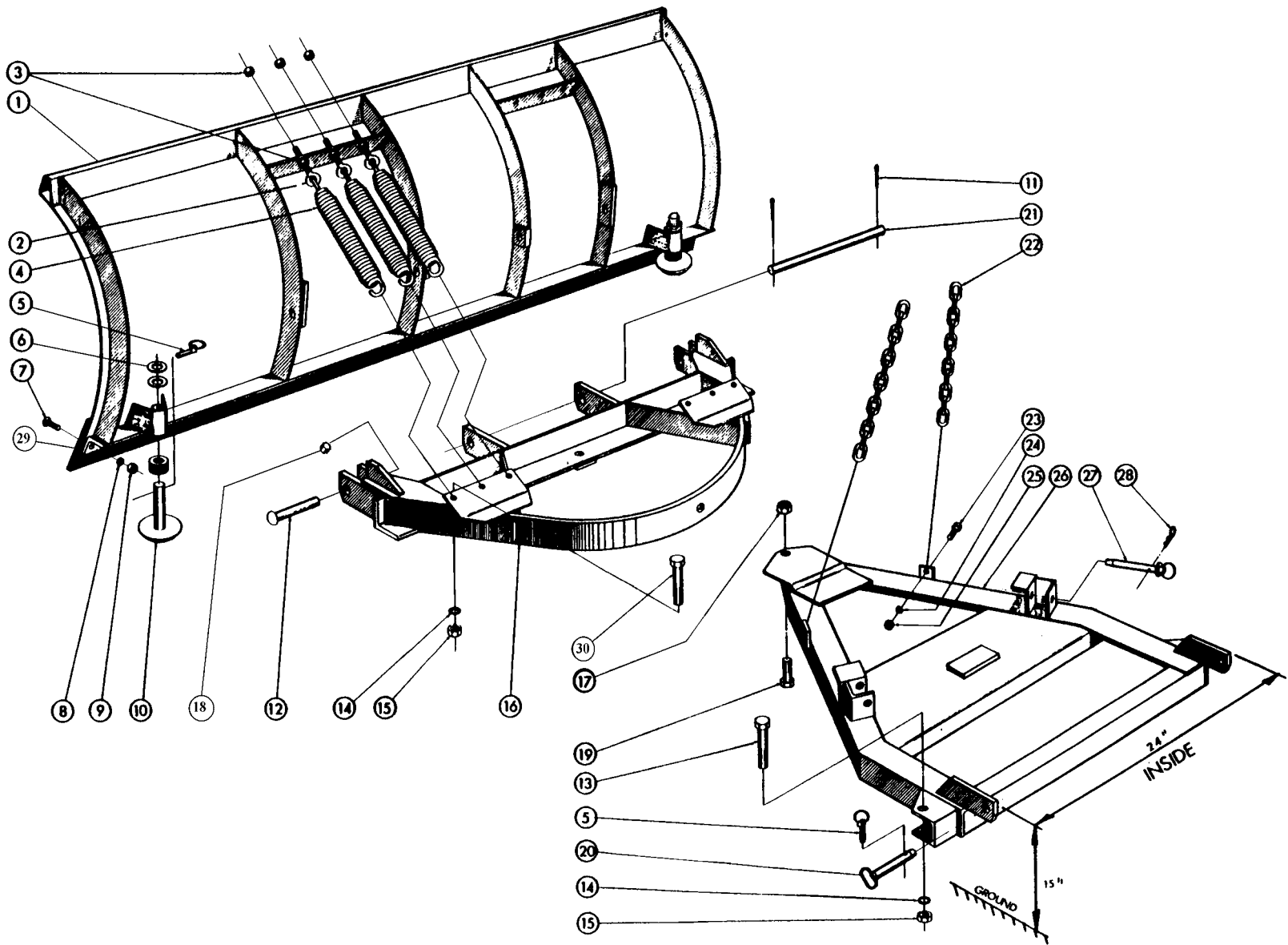

Arctic Extra Heavy Duty Steel Blade 120", Quadrant & A-frame Installation

INSTALLATION INSTRUCTIONS

1. Lay blade face down on the floor. Attach quadrant (13) to blade by inserting blade pivot bar (4) through holes in quadrant lugs and two blade centre ribs. Because of narrow spacing of blade ribs holding spring bracket, pivot bar has to be inserted through the outside rib and quadrant lugs first and then pushed into its place through two blade centre ribs. Secure bar (4) with two cotter pins (5).
2. Insert two bolts (3) through quadrant outer brackets and corresponding holes on blade ribs. Secure bolts with nylon insert locknut (12).
3. Take an eye bolt (1) and screw one nut all the way down the thread. Attach spring (2) to one of three holes in quadrant spring bracket and to eye bolt (1), lift quadrant and insert eye bolt through corresponding hole in blade spring mounting bracket (see diagram). Secure eye bolt with another nut. Repeat with remaining five springs and eye bolts.
4. Put tension on springs (2) by tightening eye bolt under nut until spring coils just break loose from each other. Secure eye bolts in position jamming lower nut against blade spring mounting bracket.
5. Attach A-frame (14) to quadrant (13) using 1" bolt (19) and nylon insert locknut (20). Make sure that A-frame is pivoting freely.
6. Lift chains (6) are attached by inserting ½" bolts (7) through chain last link and hole in A-frame lifting lugs. Tighten firmly nuts (8) over lock washer (9). Lock washer and nut must be placed on the lug face, not on the chain link.

For installation instruction of power angling cylinders follow procedure described on separate sheet.

To attach snow plow to the vehicle mount, proceed as follows:

1. Position the vehicle such that the A-frame lugs and vehicle mount are in vertical alignment.
2. Hook the chains into the lift channel slots.
3. Actuate lift cylinder slowly. Blade will remain on the ground, A-frame will begin to rise. Continue until the A-frame lug holes align with the holes on the vehicle mount.
4. Insert the spreader pins (10) to attach A-frame to the vehicle mount. Secure attachment by inserting the lynch pins (11) into the spreader pins.
5. Connect the quick couplings on hydraulic hoses.
6. With the control switch in the DOWN position, push the lift channel downward as far as possible and adjust the chain so there are two links of slack.
7. Check cutting edge clearance. Use combination of spacers until ½" clearance between ground and cutting edge is achieved. Secure shoes by inserting the quick release pins into the shoe stems.

Heavy Duty Blade				
Item	Part Number	Description	Quantity	
			Hardware Kit 51131-M	*Power Angling Ass'y 51168-M
1	50191-M	Eye Bolt ass'y (eye bolt & 2 5/8" hex nuts)	6	
2	50180-C	Trip Spring	6	
3	HH-00972-187	Hex Head Cap Screw 1" x 3.1/2"	2	
4	51169-A	Blade Pivot Bar	1	
5	HH-00020-164	Cotter Pin, 1/4Dx1.1/2L	2	
6	55018-M	Chain	2	
7	HH-00972-090	Hex Head Cap Screw 1/2-20x1.1/2	2	
8	HH-00457-001	1/2 Lockwasher	2	
9	HH-00460-002	1/2-20 Hex Nut	2	
10	50853-A	Spreader Pin	2	
11	50040-A	Lynch Pin	2	
12	HH-00540-009	1-12 Nylon Insert Locknut	2	
13	51125-D	Extra Heavy Duty Quadrant		1
14	51123-D	Extra Heavy Duty A-frame		1
15	CS200-16.00-NRS	Angling Cylinder HD 2"x16"		2
16	HH-00972-190	Hex Head Cap Screw 1-12x4.1/2		2
17	HH-00457-009	1" Lock washer		4
18	HH-00460-010	1-12 Hex Nut		4
19	HH-00972-185	Hex Head Cap Screw 1-12x3		1
20	HH-00540-009	1-12 Nylon Insert		1
21	HH-00972-191	Hex Head Cap Screw 1-12x5		2

*Power Angling Assembly 51168-M comes assembled from Arctic Equipment.

