

**Arctic Equipment Manufacturing Corporation**

Arctic PP-S

---

Table of Contents

Arctic Plow Partner Steel Blade 84" & 90" .....2  
Plow Partner Mounting Kit.....8

## ARCTIC PP-S

# Arctic Plow Partner Steel Blade 84" & 90"

\*To find detailed instructions look under Mounting kits, Miscellaneous and Mounting kit 51191-M

# ARCTIC PLOW PARTNER STEEL BLADE 84" & 90"

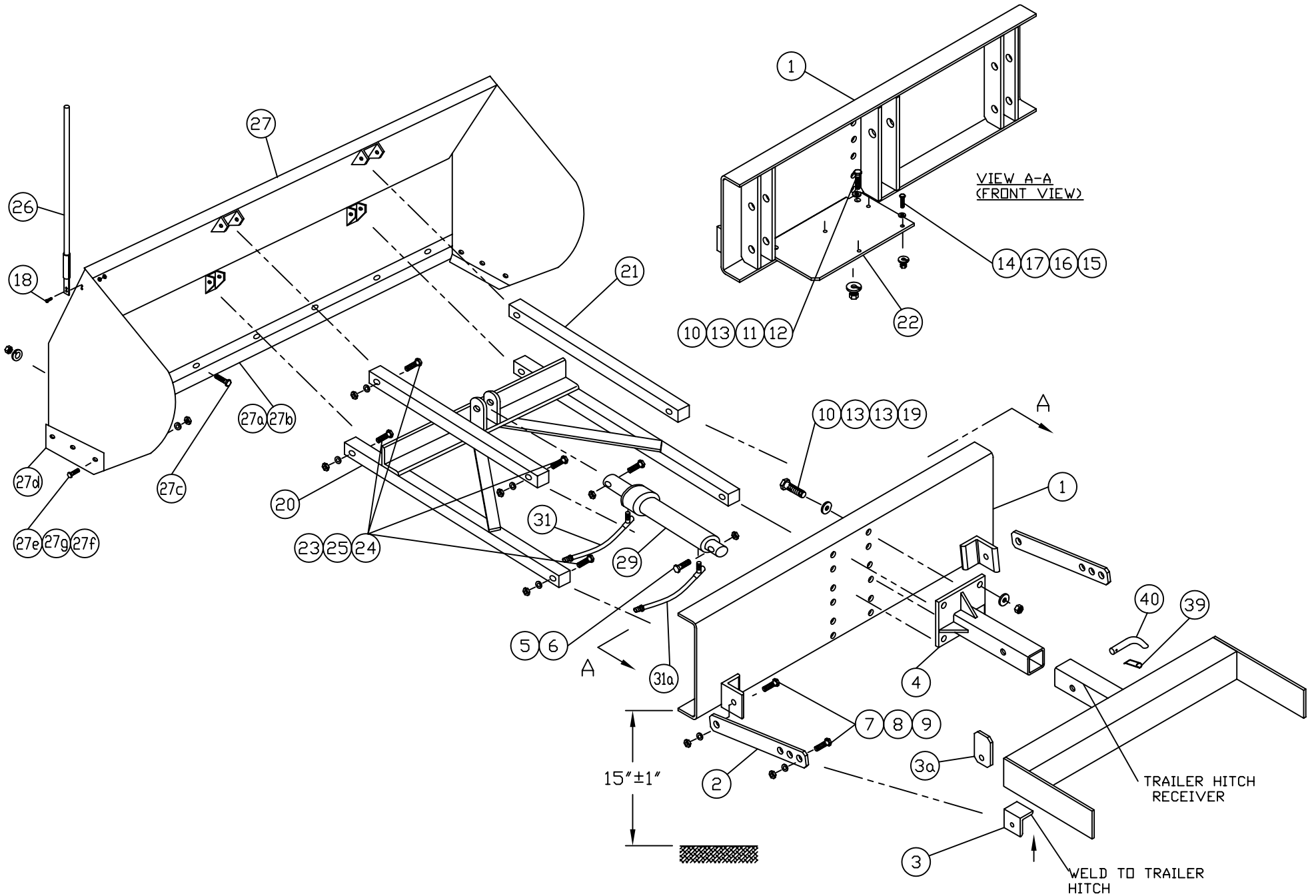

<b>Arctic Plow Partner Mounting Kit 51191-M, Blade Kit 51041-D and 52492-M Power Unit Kit</b>						
<b>Item</b>	<b>Part Number</b>	<b>Description</b>	<b>51191-M Mounting Kit</b>	<b>51041-84-D 51041-90-D Blade Kit</b>	<b>52492-M Power Unit Kit</b>	<b>*Bolt Bag 51191-A- BB</b>
1	51051-C	Rear Frame	1			
2	52401-A	Side Brace	2			
3	51054-B	Frame Mounting Angle	2			
3a	52511-A	Mounting Plate	2			
4	52399-B	Pintle Mount	1			
5	HH-00972-151	3/4" x 3" Cap screw				2
6	HH-00973-007	3/4" Lock nut				2
7	HH-00972-146	3/4" x 1 3/4" Cap screw				4
8	HH-00457-008	3/4" Lock washer				4
9	HH-00460-007	3/4" Hex nut				4
10	HH-00972-091	1/2" x 1 3/4" Cap screw				6
11	HH-00457-001	1/2" Lock washer				2
12	HH-00460-002	1/2" Hex nut				2
13	HH-00341-006	1/2" Flat washer				10
14	HH-00972-028	5/16" x 1" Cap screw				4
15	HH-00460-005	5/16" Hex nut				4
16	HH-00457-007	5/16" Lock washer				4

<b>Arctic Plow Partner Mounting Kit 51191-M, Blade Kit 51041-D and 52492-M Power Unit Kit</b>						
<b>Item</b>	<b>Part Number</b>	<b>Description</b>	<b>51191-M Mounting Kit</b>	<b>51041-84-D 51041-90-D Blade Kit</b>	<b>52492-M Power Unit Kit</b>	<b>*Bolt Bag 51191-A- BB</b>
17	HH-00341-003	5/16" Flat washer				4
18	GB001	1/4"x 1" Bolt Kit (includes two kits)				2
19	HH-00540-004	½" Locknut				4
20	51047-D	Lift Frame	1			
21	51056-A	Lift Arm	2			
22	52316-B	Power Unit Mounting Plate	1			
23	HH-00972-134	5/8" x 3" Cap screw				8
24	HH-00460-001	5/8" Nut				8
25	HH-00457-003	5/8" Lock washer				8
26	50999-B	Guides	2			
27	51041-84-D or 51041-90-D	Blade (frame, cutting edges & bolts)		1		
27a	51044-84-B	Cutting Edge 84"		1		
27b	51044-90-B	Cutting Edge 90"		1		
27c	55013-N	½" x 1 1/2" Carriage Bolt Assy		8		
27d	51045-A	Side Guard		2		

<b>Arctic Plow Partner Mounting Kit 51191-M, Blade Kit 51041-D and 52492-M Power Unit Kit</b>						
<b>Item</b>	<b>Part Number</b>	<b>Description</b>	<b>51191-M Mounting Kit</b>	<b>51041-84-D 51041-90-D Blade Kit</b>	<b>52492-M Power Unit Kit</b>	<b>*Bolt Bag 51191-A- BB</b>
27e	HH-00293-049	3/8" x 1" Cap Screw		6		
27f	HH-00294-003	3/8" Hex Nut		6		
27g	HH-00457-004	3/8" Lock washer		6		
*28	M3551-12V	Plow Partner Power Unit			1	
29	CD150-05.00-NRS	Cylinder			1	
*30	52591-A	Power cable, Power Unit Section			1	
31	51002-M	1/4"x18" Hose Assy			1	
31a	51904-M	1/4" x 29" Hose Assy			1	
*33	52427-N	Red Terminal Protector			1	
*35	52322-N	Cover for M3551			1	
*36	52592-A	Power Cable, Truck Section			1	
**37	FP17757	Solenoid			1	
*38	51335-M	Power Cable 78"			1	
39	51830-01-N	Safety pin	1			
40	51830-N	5/8" x 2"long, spreader pin/hitch pin	1			
<b>Note:</b> Bolt bag comes with 51191-M assembly						

**Arctic Equipment Manufacturing Corporation**  
Arctic PP-S

51041-84-D R05  
INST0021

---

- \*Item not shown on drawing
- \*\*Item replaces part # FP7518

Plow Partner Mounting Kit  
51191-M

**PLOW PARTNER MOUNTING KIT**  
**51191-M & BLADE KIT 51041-D**  
**FOR 84" & 90"**

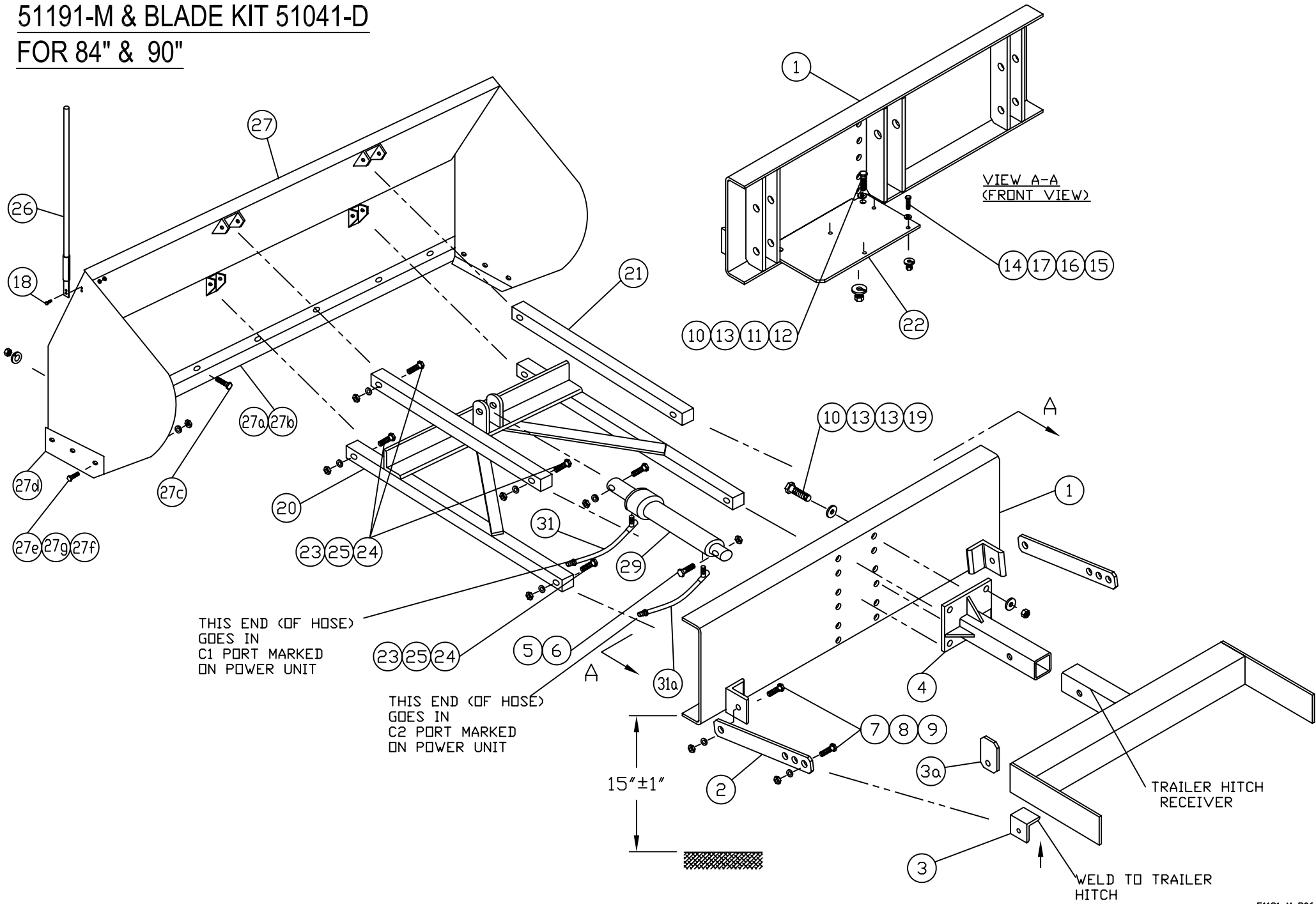

<b>Plow Partner Mounting Kit 51191-M, Blade Kit 51041-D and 52492-M Power Unit Kit</b>						
<b>Item</b>	<b>Part Number</b>	<b>Description</b>	<b>51191-M Mounting Kit</b>	<b>51041-84-D 51041-90-D Blade Kit</b>	<b>52492-M Power Unit Kit</b>	<b>* Bolt Bag 51191- A-BB</b>
1	51051-C	Rear Frame	1			
2	52401-A	Side Brace	2			
3	51054-B	Frame Mounting Angle	2			
3a	52511-A	Mounting Plate	2			
4	52399-B	Pintle Mount	1			
5	HH-00972-151	3/4" x 3" Cap screw				2
6	HH-00973-007	3/4" Lock nut				2
7	HH-00972-146	3/4" x 1 3/4" Cap screw				4
8	HH-00457-008	3/4" Lock washer				4
9	HH-00460-007	3/4" Hex nut				4
10	HH-00972-091	1/2" x 1 3/4" Cap screw				6
11	HH-00457-001	1/2" Lock washer				2
12	HH-00460-002	1/2" Hex nut				2
13	HH-00341-006	1/2" Flat washer				10

**Arctic Equipment Manufacturing Corporation**  
 Plow Partner Mounting Kit 51191-M

51191-M R08  
 April 25, 2002

<b>Plow Partner Mounting Kit 51191-M, Blade Kit 51041-D and 52492-M Power Unit Kit</b>						
<b>Item</b>	<b>Part Number</b>	<b>Description</b>	<b>51191-M Mounting Kit</b>	<b>51041-84-D 51041-90-D Blade Kit</b>	<b>52492-M Power Unit Kit</b>	<b>* Bolt Bag 51191- A-BB</b>
14	HH-00972-028	5/16" x 1" Cap screw				4
15	HH-00460-005	5/16" Hex nut				4
16	HH-00457-007	5/16" Lock washer				4
17	HH-00341-003	5/16" Flat washer				4
18	GB001	1/4"x 1" Bolt Kit (includes two kits)				2
19	HH-00540-004	1/2" Lock nut				4
20	51047-D	Lift Frame	1			
21	51056-A	Lift Arm	2			
22	52316-B	Power Unit Mounting Plate	1			
23	HH-00972-134	5/8" x 3" Cap screw				8
24	HH-00460-001	5/8" Nut				8
25	HH-00457-003	5/8" Lock washer				8
26	50999-B	Guides	2			
27	51041-84-D	Blade (includes frame, cutting edges & all bolts)		1		
	51041-90-D	Blade (includes frame, cutting edges & all bolts)				
27a	51044-84-B	Cutting Edge 84"		1		

**Arctic Equipment Manufacturing Corporation**  
 Plow Partner Mounting Kit 51191-M

51191-M R08  
 April 25, 2002

<b>Plow Partner Mounting Kit 51191-M, Blade Kit 51041-D and 52492-M Power Unit Kit</b>						
<b>Item</b>	<b>Part Number</b>	<b>Description</b>	<b>51191-M Mounting Kit</b>	<b>51041-84-D 51041-90-D Blade Kit</b>	<b>52492-M Power Unit Kit</b>	<b>* Bolt Bag 51191- A-BB</b>
27b	51044-90-B	Cutting Edge 90"		1		
27c	55013-N	½" x 1 ½" Carriage Bolt Assy		8		
27d	51045-A	Side Guard		2		
27e	HH-00293-049	3/8" x 1" Cap Screw		6		
27f	HH-00294-003	3/8" Hex Nut		6		
27g	HH-00457-004	3/8" Lockwasher		6		
*28	M3551-12V	Plow Partner Power Unit			1	
29	CD150-05.00-NRS	Cylinder			1	
*30	52591-A	Power cable, Power Unit Section			1	
31	51002-M	1/4"x18" Hose Assy			1	
31a	51904-M	1/4" x 29" Hose Assy			1	
*33	52427-N	Red Terminal Protector			1	
*35	52322-N	Cover for M3551			1	
*36	52592-A	Power Cable, Truck Section			1	
**37	FP17757	Solenoid			1	
38	51335-M	Power Cable 78"			1	

<b>Plow Partner Mounting Kit 51191-M, Blade Kit 51041-D and 52492-M Power Unit Kit</b>						
<b>Item</b>	<b>Part Number</b>	<b>Description</b>	<b>51191-M Mounting Kit</b>	<b>51041-84-D 51041-90-D Blade Kit</b>	<b>52492-M Power Unit Kit</b>	<b>* Bolt Bag 51191-A-BB</b>
39	51830-B	5/8" x 2" long LD spreader pin / jack pin assembly	1			
<b>Note:</b> Bolt bag comes with 51191-M assembly						

\*Items not shown on drawing  
 \*\*Item replaces part # FP7518

The Plow Partner mounting kit is designed to be adapted to most makes and models of four wheel drive trucks (with a trailer hitch). The following instructions are a general guide.

**GENERAL**

**Customer must be aware of following:**

Arctic Equipment Manufacturing Corporation (Arctic) does not assume liability for damage to your motor vehicle resulting from the attachment or use of an Arctic snowplow. The purchaser assumes all vehicle risk associated with the attachment and operation of this snowplow.

The Arctic snowplow you purchase must be used only on vehicles equipped with the manufacturer's snow plow preparation package. Snow plowing without the original plow preparation package may damage your vehicle. The added weight may impair the operation and control of your vehicle. Snow plowing with a vehicle not recommended for that purpose by the manufacturer may void your new vehicle warranty. If your vehicle is not equipped with an original snow plow preparation package, additional equipment may be necessary before snow plowing. Please consult your vehicle and snowplow dealers prior to the purchase and installation of the snowplow. The installation of such parts however is not a full substitute for the

original equipment snowplow preparation package.

CAUTION: Always disconnect battery before beginning installation.

All bolts have to be inserted from inside of truck frame so that lockwasher and nut are accessible for retightening.

If a slotted hole in the truck frame is utilized, then a flat washer must be used under the bolt head. If a flat washer is used under a lock washer use LOCTITE #242.

Do not tighten bolts and nuts until all fasteners are in place and installation is complete, unless otherwise specified.

### **Installation Instructions**

1. Insert the pintle mount (4) into the trailer hitch (not included in kit) and insert the pin to lock it in place.
2. Move the rear frame weldment to a position that the trailer hitch receiver is centred, and the bottom of it is  $15" \pm 1"$  from the ground.
3. Insert four  $1/2"$  bolts (10), flatwashers (13), and locknut (19). Tighten all four bolts.
4. Take the side braces (2) and bolt them to the rear frame weldment using  $3/4" \times 1-3/4"$  bolts (7),  $3/4"$  lockwashers (8), and  $3/4"$  hex nuts (9). Remember not to tighten the bolts.
5. Using one of the provided holes on the other end of the side braces, bolt the frame mounting angles (3) to the side braces, using  $3/4" \times 1-3/4"$  bolts (7),  $3/4"$  lock washers (8), and hex nuts (9). Remember not to tighten the bolts.
6. Move the frame mounting angles (3) to a position on the trailer hitch frame cross tube (already attached to the truck). The frame mounting angle position may vary for each type of trailer hitch package. There may be some moving around of the frame mounting angle (3) on the side brace (2) so that it will get welded in a desired position on the trailer hitch package. (Note: If there is not enough room to weld frame mounting brackets (3), mounting brackets (3a) needs to be used).

7. Weld the frame mounting angles (3) to the trailer hitch frame cross tube (or mounting brackets (3a) if mounting angle can't be used).
8. After the metal has cooled, tighten all bolts.
9. Install one side of lift frame (20) to rear frame (1) and second side to blade (27) as shown with 5/8" bolts (23), lock washer (25) and nut (24).
10. Repeat same step with lift arm (21). Tighten all bolts.
11. Install guides (26) to blade using 1/4" bolt kit (18).

#### **Hydraulic and Electrical Installation of power unit M3551\***

---

**Warning:**

- Top of battery needs to be protected. If positive side of battery is accidentally grounded person could be burnt or wiring system can be damaged, or battery gasses could explode causing injuries.
  - Disconnect cable from negative battery terminal before replacing the motor or solenoid.
  - Always wear eye protection and protective clothing when working around hydraulic systems.
  - Remove jewelry and objects that might conduct electricity while working on power units.
  - Fluid under pressure can pierce the skin and enter the bloodstream causing death or serious injury.
- 

1. Attach the pump mounting bracket (22) to the rear frame (1) using two 1/2" x 1 3/4" bolts (10), 1/2" flat washer (13), 1/2" lock washers (11), and 1/2" hex nuts (12). Attach the power unit to the pump mounting bracket (22) using four 5/16" bolts (14), 5/16" flat washers (17), 5/16" hex nuts (15) and 5/16" lock washers (16). The power unit should be sitting so that the motor is pointing to the centre of the rear frame.
2. Remove the plugs from ports C1 and C2. Port C1 should be facing out, while port C2 should be facing in. Attach the 90° elbows to ports C1 and C2.

3. Attach the 29" hose to the 90° elbow in port C2. Attach the 18" hose to the 90° elbow in port C1.
4. Attach the non-extending end of the cylinder (29) to the middle lug of the rear frame using a 3/4"x3" bolt (5) and 3/4" (6) lock hex nut.
5. Attach the other end of the 29" hose to the non-extending end port of the cylinder. Make sure to use some pipe sealant to seal the connection properly.
6. Attach the extending end of the cylinder to the middle lug of the plow partner blade using a 3/4"x3" bolt (5) and 3/4" (6) lock hex nut.
7. Attach the other end of the 18" hose to the extending end port of the cylinder. Make sure to use some pipe sealant to seal the connection properly.



Using the power unit wiring diagram:

8. Mount solenoid (37) in a convenient location, bending bracket if necessary.
9. Connect power cable (38) to battery and to live side of solenoid.
10. Red cable of power cable (truck section) (36) is to be attached to second pole on solenoid (opposite of live solenoid side) and black cable to be attached to negative side of battery.
11. Attach power cable (power unit section) (30) to the power cable (36) (truck section) and run red cable to motor of power unit and black wire to be attached to bolt that holds power unit to mounting plate (Note: Paint must be removed on the bottom side of this mounting hole in order to provide ground).
12. Feed the control box cable through the firewall from the cab into the engine compartment.
13. Attach the black wire from the control box cable to the live side of the solenoid. Attach the white wire from the control box cable to the small terminal on the solenoid.

14. Run the two 22' cables from the engine compartment to the plow partner pump. Attach the red and green wire from the 22' two wire cable in the engine compartment to the matching two wires from the control box cable. These cannot be mixed up, as only one of the connectors will fit with its corresponding connector.
15. Connect the red and green wires from the other end of the 22' two wire cable to the plow partner power unit. These cannot be mixed up, as only one of the connectors will fit with its corresponding connecting wire on the pump.
16. Fill up power unit with UNIVS J13 oil approximately 1/2" from the top. Grease motor bolt and apply protective cover (33) over that bolt.

17. Apply cover (35) on power unit

\* Refer to hydraulic power unit kit information M3551.

TORQUE CHART (FT. L.B.)		
SIZE	GRADE 5 BOLT 	GRADE 8 BOLT 
1/4 - 28	8	11
5/16 - 24	15	22
3/8 - 24	28	40
7/16 - 20	44	63
1/2 - 20	69	97
5/8 - 18	138	195
3/4 - 16	241	341
Note: Torque values are for plated bolts only		