

MOUNTING KIT

53211-MKPB

W1500 Ram 4x4 (Except Sport) 2002-2008

(Note: For the snowplow (W1500 Ram 4x4 (Except Sport) 2002-2005) lights this kit requires:
800037AXV Light kit, 767052 Adapter Kit (vehicle's headlamp bulb H9007

For the snowplow lights (W1500 Ram 4x4 (Except Sport) 2006-2008) this kit requires: 800037AXV
Light kit, 800034 Adapter (vehicle's headlamp bulb H13) and Turn Signal Relay Kit 800038)

MOUNTING KIT 52311-MKPB-QLII 2002-2005

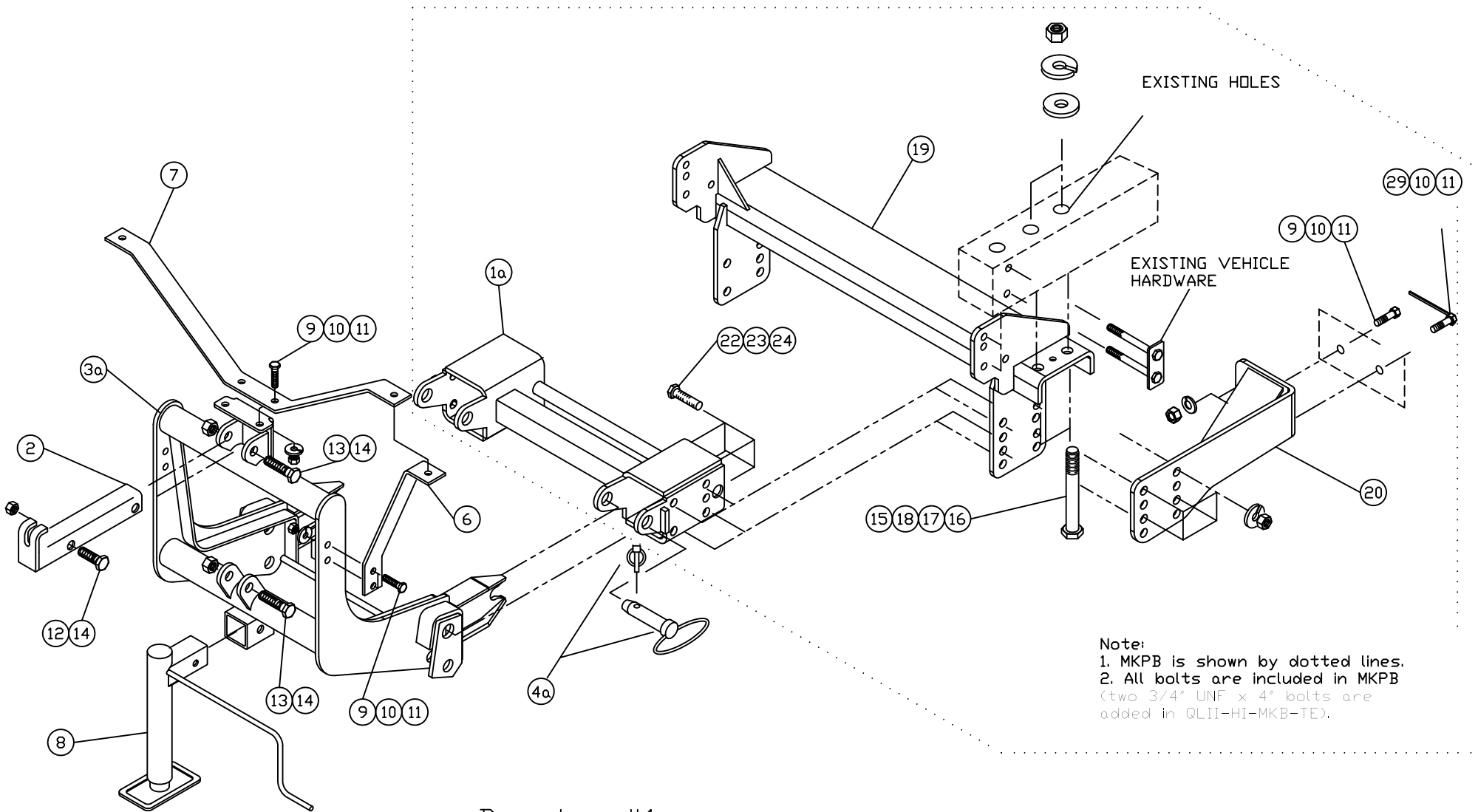

Drawing #1

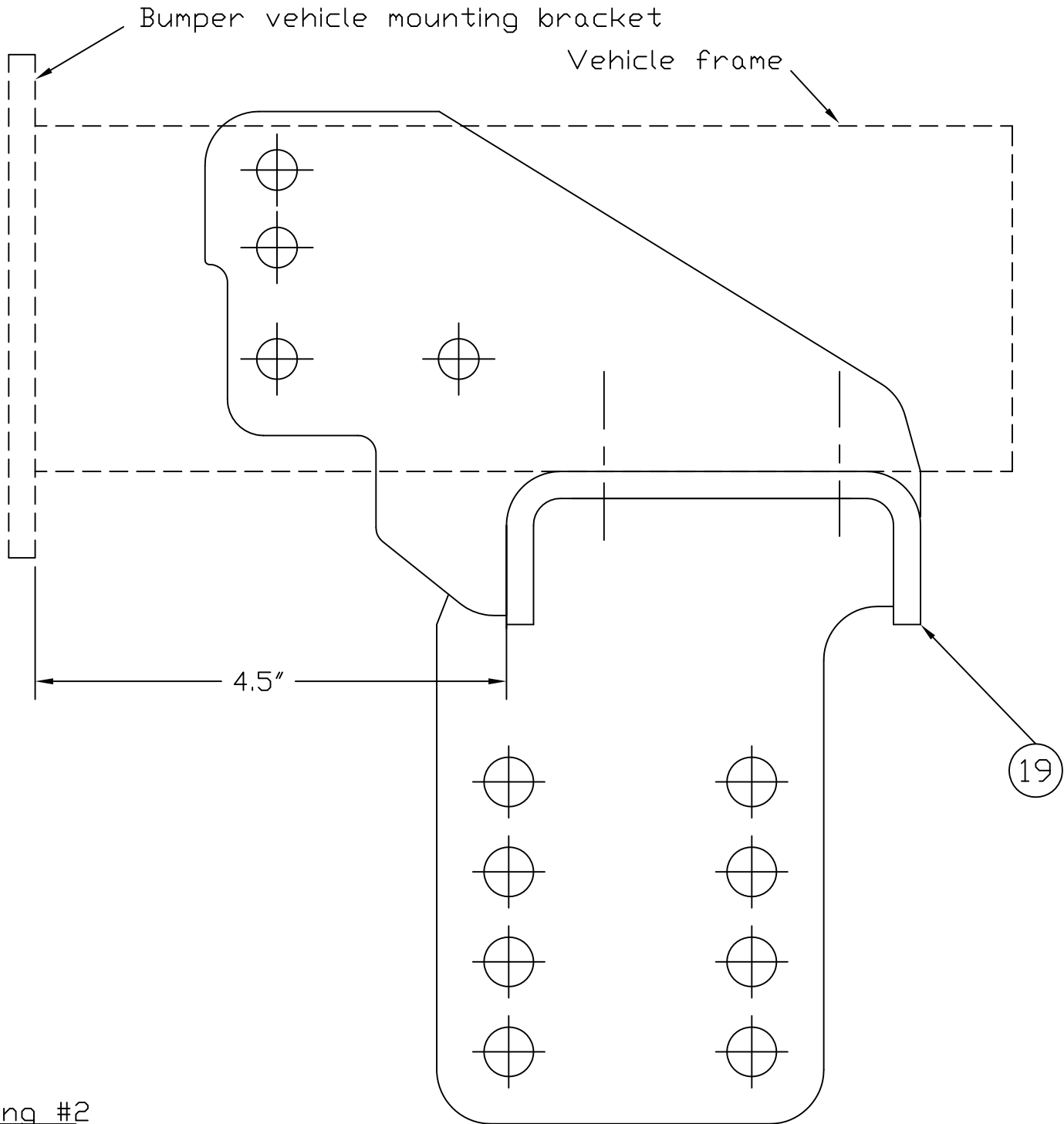

Drawing #2

MOUNTING KIT 53211-MKPB-QLII 2006-2008

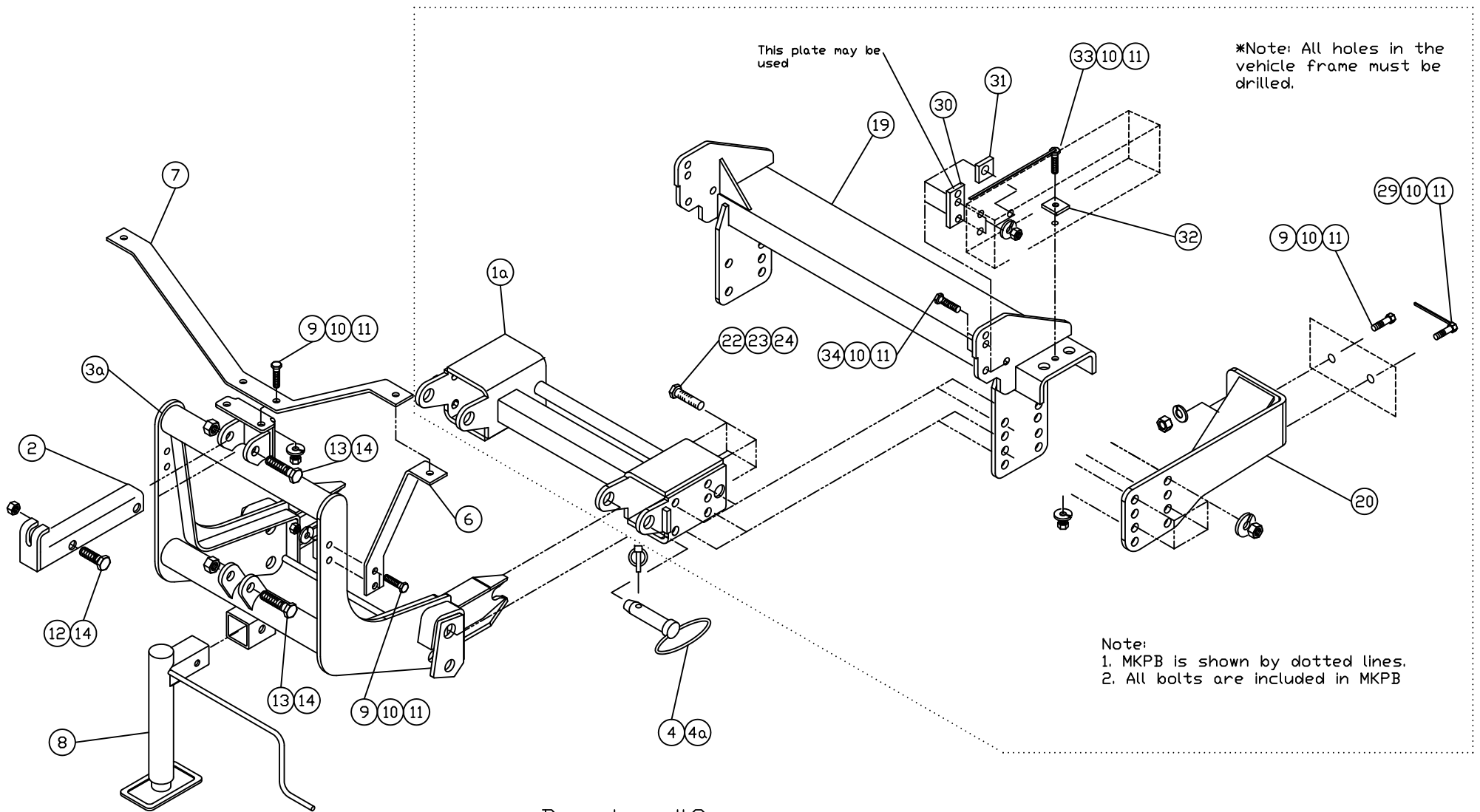

Drawing #3

Arctic Equipment Manufacturing Corporation

53211-MKPB R08

Mounting kit 53211-MKPB

Quik-link Mounting Kit 53211-MKPB							
Item	Part #	Description	MKPB	MKPB-QLII	QL-MKB	QLII-MKB	QLII-HI-MKB
1*	52166-C	Spreader Bar	1				
1a	52363-C	Spreader Bar QLII		1			
2	50069-C	Lift Channel			1		
3*	52162-C	Lift Frame			1		
3a	52365-D	Lift Frame, QLII				1	
3b*	52430-D	Lift Frame, QLII-Hi boy					1
4*	WA-34704-M	Mounting Pin, QLI, Ass'y			2		
4a	52348-M	Mounting Pin, Ass'y			2		
6	52208-B	Light Brace			2		
7	52209-B	Light Antler			1		
8	52373-M	Jack Assembly				1	
9	HH00972-090	½" x 1 ½" UNF Hex Head Capscrew	8				

Arctic Equipment Manufacturing Corporation

53211-MKPB R08

Mounting kit 53211-MKPB

Quik-link Mounting Kit 53211-MKPB							
Item	Part #	Description	MKPB	MKPB-QLII	QL-MKB	QLII-MKB	QLII-HI-MKB
10	HH-00457-001	½" Lock washer	18				
11	HH-00460-002	½" UNF Nut	18				
12	HH-00972-149	¾" x 2 ½" UNF Hex Head Cap screw	1				
13	HH-00972-153	¾" x 3 ½" UNF Hex Head Cap screw	2				
14	HH-00973-007	¾" UNF Thin Collar Locknut	3				
15	52609-N	¾" x 7 ½" UNF Hex Head Cap screw	4				
16	HH-00460-007	¾" UNF Nut	4				
17	HH-00457-008	¾" Lock washer	4				
18	HH-00341-009	¾" Flat washer	4				
19	52602-C	Mounting Bracket	1				
20	52597-01-B	Thrust Arm, Driver Side	1				
21*	52597-02-B	Thrust Arm, Curb Side	1				
22	HH-00972-131	5/8" x 2 1/4" UNF Hex Head Cap screw	8				
23	HH-00457-003	5/8" Lock washer	8				

Arctic Equipment Manufacturing Corporation

53211-MKPB R08

Mounting kit 53211-MKPB

Quik-link Mounting Kit 53211-MKPB							
Item	Part #	Description	MKPB	MKPB-QLII	QL-MKB	QLII-MKB	QLII-HI-MKB
24	HH-00460-001	5/8" Hex Nut	8				
25*	HH-00293-006	1/4"x1" UNC Hex Head Cap screw	4				
26*	HH-00341-002	1/4" Flat washer	4				
27*	HH-00457-006	1/4" Lock washer	4				
28*	HH-00294-001	1/4" Hex Nut	4				
29	52575-A	1/2" x 1 1/2" Hex Head Cap screw c/w Welded Handle	2				
30	53209-A	Spacer, side plate	2				
31	53331-A	Spacer 3/8"	2				
32	53332-A	Frame Plate 1/4"	2				
33	52575-12-A	Bolt 1/2" x 10" with welded handle	2				
34	HH00972-092	1/2" x 2" UNF Hex Head Capscrew	6				

Note: * These items are not shown on the drawing.

GENERAL

Customer must be aware of following:

Arctic Equipment Manufacturing Corporation (Arctic) does not assume liability for damage to your motor vehicle resulting from the attachment or use of an Arctic snowplow. The purchaser assumes all vehicle risk associated with the attachment and operation of this snowplow.

The Arctic snowplow you purchase must be used only on vehicles equipped with the manufacturer's snow plow preparation package. Snow plowing without the original plow preparation package may damage your vehicle. The added weight may impair the operation and control of your vehicle. Snow plowing with a vehicle not recommended for that purpose by the manufacturer may void your new vehicle warranty. If your vehicle is not equipped with an original snow plow preparation package, additional equipment may be necessary before snow plowing. Please consult your vehicle and snowplow dealers prior to the purchase and installation of the snowplow. The installation of such parts however is not a full substitute for the original equipment snowplow preparation package.

Before drilling any holes in the firewall or frame, move brake lines, fuel lines and/or electrical wiring from the path of the drill. Brake and fuel lines must also be clear of any fasteners.

All bolts should be installed from the inside of the truck frame so that the lock washers and nuts are accessible for re tightening (where is possible).

If a slotted hole in the truck frame is utilized, then a flat washer must be used under the bolt head. If a flat washer is used under a lock washer use LOCTITE #242. Also use this LOCTITE #242 if existing (vehicle) bolts and nuts are used.

General order of installation:

- install all components (mounting bracket, thrust arm and spreader bar) and all fasteners finger tight (snug) through existing holes,
- drill necessary holes and
- tighten all hardware.

After first use, re tighten all mounting bolts, thereafter check mounting bolt tightness periodically and at the start of the season.

For easier installation, grind ONLY the paint out of the top holes of the spreader bar and the top hole of the lift frame, where the mounting pins will go.

Before proceeding, read instructions carefully and familiarize yourself with the components and hardware.

INSTALLATION INSTRUCTIONS

1. DO NOT REMOVE a bumper for W1500 Ram 4x4 2002-2005 from truck. REMOVE a bumper for W1500 Ram 4x4 2006-2008 from truck. Remove plastic moulded dam attached to the bumper vehicle.

For W1500 Ram 4x4 (Except Sport) 2002-2005 see drawing #1:

Remove the bumper mounting bolts from the inside of the frame rails and partially reinsert from outside the frame. Be sure that the bolts do not extend past the inboard edge of the bumper mounting bracket

3. Slide spreader bar mounting bracket (19) up between the bumper mounting brackets. Align the 2 top holes in the bracket with the existing bumper mounting bolts. Push the bumper mounting bolts fully through the spreader bar mounting bracket. Reinstall original hex nuts using Loctite # 242.
4. Install two 3/4" x 7 1/2" (15) bolts , flat washer (18) , lock washer (17) and 3/4" nut (16) on each side of frame. Apply LOCTITE # 242 on these four bolts.

For W1500 Ram 4x4 (Except Sport) 2006-2008 see drawing #2 and #3:

- 3a. Slide mounting bracket (19) against vehicle frame. Mounting bracket channel (19) must be 4.5" away from the bumper mounting bracket-see drawing #2. Assure that thrust arms (20)(21) sit against the truck cross member and line up with four holes in the mounting bracket (19). Insert 3/8" spacer (30) and (31) so that mounting bracket (19) is centred between frame rails. Insert three 1/2" x 2" bolts per side (34) and secure with 1/2" lockwasher (10) and 1/2" nut (11). Using 9/16" hole in the mounting bracket (19) as guide, drill 25/32" hole per side through the bottom of the vehicle frame.
- 4a. Place 1/4" spacer (33) as shown on the drawing #3. Insert 1/2" bolt with welded handle 10" (33) through the vehicle frame and secure with 1/2" lock washer (10) and 1/2" nut (11). Assure again that thrust arms (20)(21) sit against the truck cross member and line up with four holes in the mounting bracket (19).

Follow instruction for W1500 *2002-2005 and 2006-2008*:



5. Using four 5/8" (22) bolts on each side install spreader bar (1)(1a) between mounting bracket.
6. Install thrust arms (20)(21) (see drawing for correct orientation of thrust arm), so that thrust arm is outside of mounting bracket (19). Install 5/8" lock washers (23) and 5/8" nuts (24) on 5/8" x 2 1/4" bolts (5/8" x 2 1/4" bolts connect together spreader bar (1)(1a), mounting bracket (19) and thrust arm (20)(21)). Drill two 17/32" holes through cross member using two holes in thrust arm as a guide. Install one 1/2" x 1 1/2" bolt (9) and 1/2" x 1 1/2" (29) bolt with welded handle, 1/2" lock washer (10) and 1/2" nut (11).
7. Torque all fasteners using torque chart.
(Note: Bumper needs to be slid up as much as possible in order to get clearance between bumper and lift frame for W1500 2002-2005). Reinstall bumper for W1500 2006-2008.
8. Install lift frame (3)(3a)(3b). Set hook tabs of lift frame (3) between mounting lugs of spreader bar (1) and lift it into position so that hook tabs are hooked under the mounting lugs for QLI or slide lift frame (3a)(3b) inside of spreader bar (1a). Insert mounting pin (4)(4a) in top holes of spreader bar (1)(1a).
9. Fasten the light antler (7) to the top of the lift frame (3)(3a) using 1/2"x1 1/2" bolt (9), lock washer (10), 1/2" nut (11). Do not tighten.
Fasten the light brace (6) to both sides of the lift frame (3)(3a), using 1/2"x1 1/2" bolt (9), lock washer (10), 1/2" nut (11). Do not tighten.
Install plow lamps so that the stud is through the light antler (7) and light brace (6).
10. Torque all fasteners according to torque chart.
11. Fasten lift channel (2) and lift cylinder to the lift frame (3)(3a)(3b) using 3/4"x3 1/2" bolts (13) and 3/4" locknut (14). Use 3/4"x 2 1/2" bolt (12) and 3/4" locknut (14) to attach lift cylinder or M673F to lift channel (2). NOTE: Do not over tighten as this assembly must be able to pivot.

Arctic Equipment Manufacturing Corporation

Mounting kit 53211-MKPB

53211-MKPB R08

12. Use 1/4"x1" bolt (25), 1/4" flat washer (26), 1/4" lock washer (27) and 1/4" hex nut (28) to fasten blade guides to plow.
13. Return any unused items to the customer so that the vehicle can be returned to its original condition if the snowplow is removed.
14. See separate installation instructions for the hydraulic pump, wiring and controls.

TORQUE CHART (FT. L.B.)		
SIZE	GRADE 5 BOLT 	GRADE 8 BOLT 
1/4 - 28	8	11
5/16 - 24	15	22
3/8 - 24	28	40
7/16 - 20	44	63
1/2 - 20	69	97
5/8 - 18	138	195
3/4 - 16	241	341
Note: Torque values are for plated bolts only		