

# MOUNTING KIT

## 52758-MKPB

Blazer 1500/Suburban 1500 4x4 1973-1991  
Suburban 2500 4x4 1973-1991  
K1500 4x4 1973-1987  
K2500 4x4 1973-1987  
K3500 SRW 4x4 1973-1987  
K3500 DRW 4x4 1973-1987

**Note:** For the snowplow lights this kit requires: 800067 or 800037AXV Light kit, and Adapter kit 767051 (vehicle's bulb # 4651, 4652, H4651, H4656) **may be required**

# MOUNTING KIT 52758-MKPB-QLII

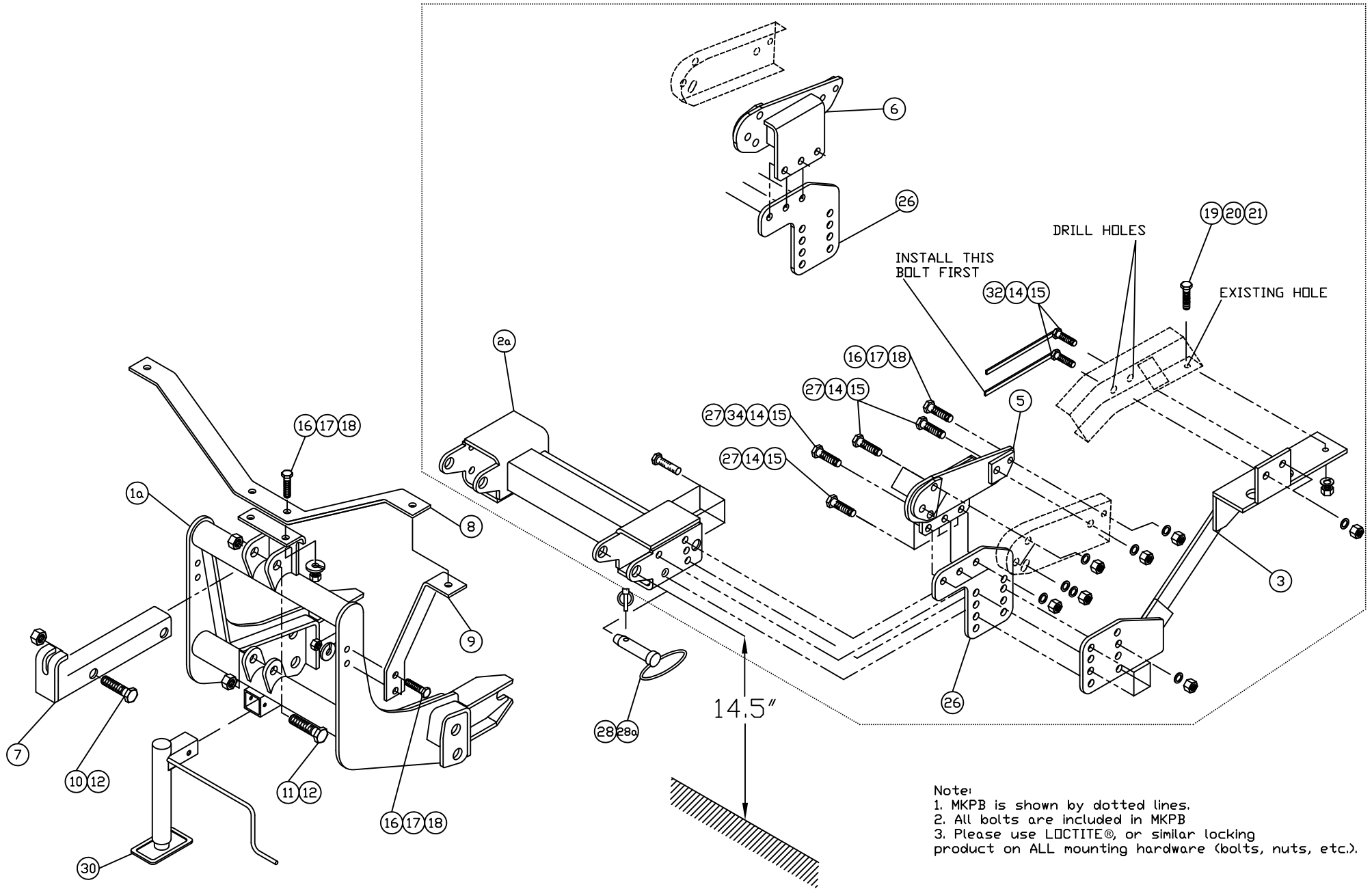

Mounting Kit 52758-MKPB								
Item	Part #	Description	MKPB	MKPB-QLII	QL-MKB	QLII-MKB	QLII-HI	QLII-HI-DLC
1*	52162-C	Lift Frame			1			
1a	53170-D-GA	Lift Frame, QUIK*LINK ® II Galvanized				1		
1b*	53171-D-GA	Lift Frame, QUIK*LINK ® II-HI Galvanized						1
2*	52166-C	Spreader Bar	1					
2a	52363-C	Spreader Bar QLII		1				
3	52766-D	Thrust Arm, Driver Side	1					
4*	52767-D	Thrust Arm, Curb Side	1					
5	52759-01-C	Top Mounting Bracket, Driver Side	1					
6	52759-02-C	Top Mounting Bracket, Curb Side	1					
7	50069-C-GA	Lift Channel Galvanized			1			
7a*	52612-B-GA	Lift Channel (2" cylinder) Galvanized						1
8	52209-B-GA	Light Antler Galvanized			1			
9	52208-B-GA	Light Brace Galvanized			2			
10	HH-00972-149	3/4" x 2½" UNF Cap screw	1					
11	HH-00972-153	3/4" x 3½" UNF Cap screw	2					
12	HH-00973-007	3/4" UNF Thin Collar Lock nut	3					

**Arctic Equipment Manufacturing Corporation**  
**Mounting kit 52758-MKPB**

52758-MKPB R08  
 INST0051

<b>Mounting Kit 52758-MKPB</b>								
<b>Item</b>	<b>Part #</b>	<b>Description</b>	<b>MKPB</b>	<b>MKPB-QLII</b>	<b>QL-MKB</b>	<b>QLII-MKB</b>	<b>QLII-HI</b>	<b>QLII-HI-DLC</b>
13	HH-00972-131	5/8" x 2.1/4" UNF Cap screw	8					
14	HH-00457-003	5/8" Lock washer	26					
15	HH-00460-001	5/8" UNF Hex nut	26					
16	HH-00972-090	1/2" x 1 1/2" UNF Cap screw	8					
17	HH-00457-001	1/2" Lock washer	8					
18	HH-00460-002	1/2" Hex nut	8					
19	HH-00972-071	7/16" x 1 1/2" UNF Cap screw	2					
20	HH-00457-011	7/16" Lock washer	2					
21	HH-00460-008	7/16" Hex nut	2					
22*	HH-00293-006	1/4" x 1" Cap screw	4					
23*	HH-00457-006	1/4" Lock washer	4					
24*	HH-00341-002	1/4" Flat washer	4					
25*	HH-00294-001	1/4" Hex nut	4					
26	52765-01-B	Bottom Mounting Bracket	2					
27	HH-00972-129	5/8" x 1 3/4" UNF Cap screw	14					
28	WA-34704-M	Mounting Pin, QLI Ass'y			2			
28a	52348-M	Mounting Pin Ass'y					2	

Mounting Kit 52758-MKPB								
Item	Part #	Description	MKPB	MKPB-QLII	QL-MKB	QLII-MKB	QLII-HI	QLII-HI-DLC
30	52373-M	Jack Assembly					1	
31*	50999-B	Blade guides				2		
32	52575-03-A	5/8" bolt with welded handle	4					
33*	HH-00972-155	3/4" x 4" UNF Cap screw						2
34	HH-00341-008	5/8" Flat washer	2					

QUIK\*LINK is a trademark of Arctic Equipment Manufacturing Corporation

**Note:** \* These items are not shown on the drawing.

**GENERAL**

**Customer must be aware of following:**

Arctic Equipment Manufacturing Corporation (Arctic) does not assume liability for damage to your motor vehicle resulting from the attachment or use of an Arctic snowplow. The purchaser assumes all vehicle risk associated with the attachment and operation of this snowplow.

The Arctic snowplow you purchase must be used only on vehicles equipped with the manufacturer’s snow plow preparation package. Snow plowing without the original plow preparation package may damage your vehicle. The added weight may impair the operation and control of your vehicle. Snow plowing with a vehicle not recommended for that purpose by the manufacturer may void your new vehicle warranty. If your vehicle is not equipped with an original snow plow preparation package, additional equipment may be necessary before snow plowing. Please consult your vehicle and snowplow dealers prior to the purchase and installation of the snowplow. The installation of such parts however is not a full substitute for the

original equipment snowplow preparation package.

Before drilling any holes in the firewall or frame, move brake lines, fuel lines and/or electrical wiring from the path of the drill. Brake and fuel lines must also be clear of any fasteners.

All bolts should be installed from the inside of the truck frame so that the lock washers and nuts are accessible for re-tightening.

If a slotted hole in the truck frame is utilized, then a flat washer must be used under the bolt head. If a flat washer is used under a lock washer use LOCTITE #242. Also use this LOCTITE #242 if existing (vehicle) bolts and nuts are used.

Do not tighten any bolt assemblies until all fasteners and components are installed, unless otherwise specified.

**After first use, re-tighten all mounting bolts**, thereafter check mounting bolt tightness periodically.

Before proceeding, read instructions carefully and familiarize yourself with the components and hardware.

### **INSTALLATION INSTRUCTIONS**

1. Remove bumper from truck.
2. One of the gas line clips that bolt on the passenger frame rail must be relocated. The bolt is roughly located above the front axle such that it will interfere with the rear thrust arm mounting plate. The clip, fuel lines, and bolt should be relocated about 1 3/4" up from the present location.
3. Install top mounting bracket (5)(6) to the vehicle frame (inside of the vehicle frame) using four 5/8" x 1 3/4" bolts (27), 5/8" lock washers (14) and 5/8" nuts (15) and one 1/2" x 1 1/2" bolt (16), 1/2" lock washer (17) and 1/2" nut (18). 5/8" flat washer (34) needs to be installed under the 5/8" lock washer for the slotted hole in the vehicle frame. Holes should be already inside of the vehicle frame, or if they are not, it may be required to drill missing holes using hole in top mounting bracket as guide or it may be required that holes need to be opened to fit bolt through.

4. Attach bottom mounting plate (26) using three 5/8" x 1 3/4" bolts (27), 5/8" lock washers (14) and 5/8" nuts (15).
5. Insert the spreader bar (2a) between two bottom mounting brackets (26). The spreader pin hole should be located 14 1/2" (+/- 1/2") off of the ground. Insert 5/8" x 2 1/4" bolts (13) from inside spreader bar through mounting bracket holes.
6. Fasten the thrust arms (3)(4) to the chassis using 7/16" x 1 1/2" bolt (19), 7/16" lock washer (20) and 7/16" nut (21) and attach thrust arms (3)(4) to the spreader bar (2a) using 5/8" x 2 1/4" bolts (13), 5/8" lock washers (14) and 5/8" nuts (15).  
 NOTE: On some models, the large hole in the bottom of the passenger side thrust arm mount may have to be trimmed slightly. This must be done in order to clear the rivet head, in the bottom of the frame.
7. Using existing holes in thrust arm (3)(4) as guide drill 21/32" hole through the vehicle frame. Insert 5/8" bolts with welded handle (32), 5/8" lock washers (14) and 5/8" nuts (15) to secure thrust arm (3)(4).
8. Torque all fasteners according to torque chart.
9. Reinstall bumper.
10. Install lift frame (1a) (1b). Slide inside of spreader bar (2a). Insert mounting pin (28a) in the top holes of the spreader bar (2a).
11. Install light antler (8) and light braces (9) using 1/2" x 1 1/2" bolts (16), 1/2" lock washers (17) and 1/2" hex nuts (18). Install lights so that the light mounting stud goes through both antler (8) and the brace (9). Tighten all light mounting hardware.
12. Install lift channel (7) and front mount pump (from hydraulic kit) or hydraulic cylinder to lift frame (1a) (1b) using 3/4" x 3 1/2" bolts (11) and 3/4" locknuts (12). Use 3/4" x 2 1/2" bolts (10) and 3/4" locknuts (12) to attach lift channel (7) to front mount pump or hydraulic cylinder. Do not over tighten this assembly as it must be able to pivot.

TORQUE CHART (FT. LB.)		
SIZE	GRADE 5 BOLT	GRADE 8 BOLT
1/4 - 28	8	11
5/16 - 24	15	22
3/8 - 24	28	40
7/16 - 20	44	63
1/2 - 20	69	97
3/8 - 18	138	195
3/4 - 16	241	341

Note: Torque values are for plated bolts only

13. Use 1/4"x 1" bolt (22), 1/4" flat washer (23), 1/4" lock washer (24) and 1/4" hex nut (25) to fasten blade guides to plow.
  
14. Return any unused items to the customer so that the vehicle can be returned to its original condition if the snowplow is removed.
  
15. See separate installation instructions for hydraulic power unit, wiring and controls.