

MOUNTING KIT

52188-MKPB

Blazer 1500/Suburban 1500/Yukon 1500/Tahoe 1500 4x4 1992-1999
Suburban 2500 Classic 4x4 1992-1999
K1500 Classic 4x4 1988-1989
K1500 Classic 4x4 1990-1998
K2500 Classic 4x4 1988-1989
K2500 Classic 4x4 1990-1998
K3500 Classic SRW 4x4 1988-1989
K3500 Classic DRW 4x4 1988-1989
K3500 Classic SRW 4x4 1990-2000
K3500 Classic DRW 4x4 1990-2000

Note: For the snowplow lights this kit requires: 800037 (or 800037AXV) Light kit, and Adapter kit:

- for vehicles 1988-1989, Adapter kit 767053 (vehicle's headlamp number H4701/H4703) may be required
- for vehicles 1990 - up, Adapter Kit 767054 (vehicle's headlamp bulb H9005/H9006) may be required

MOUNTING KIT 52188-MKPB-QLII

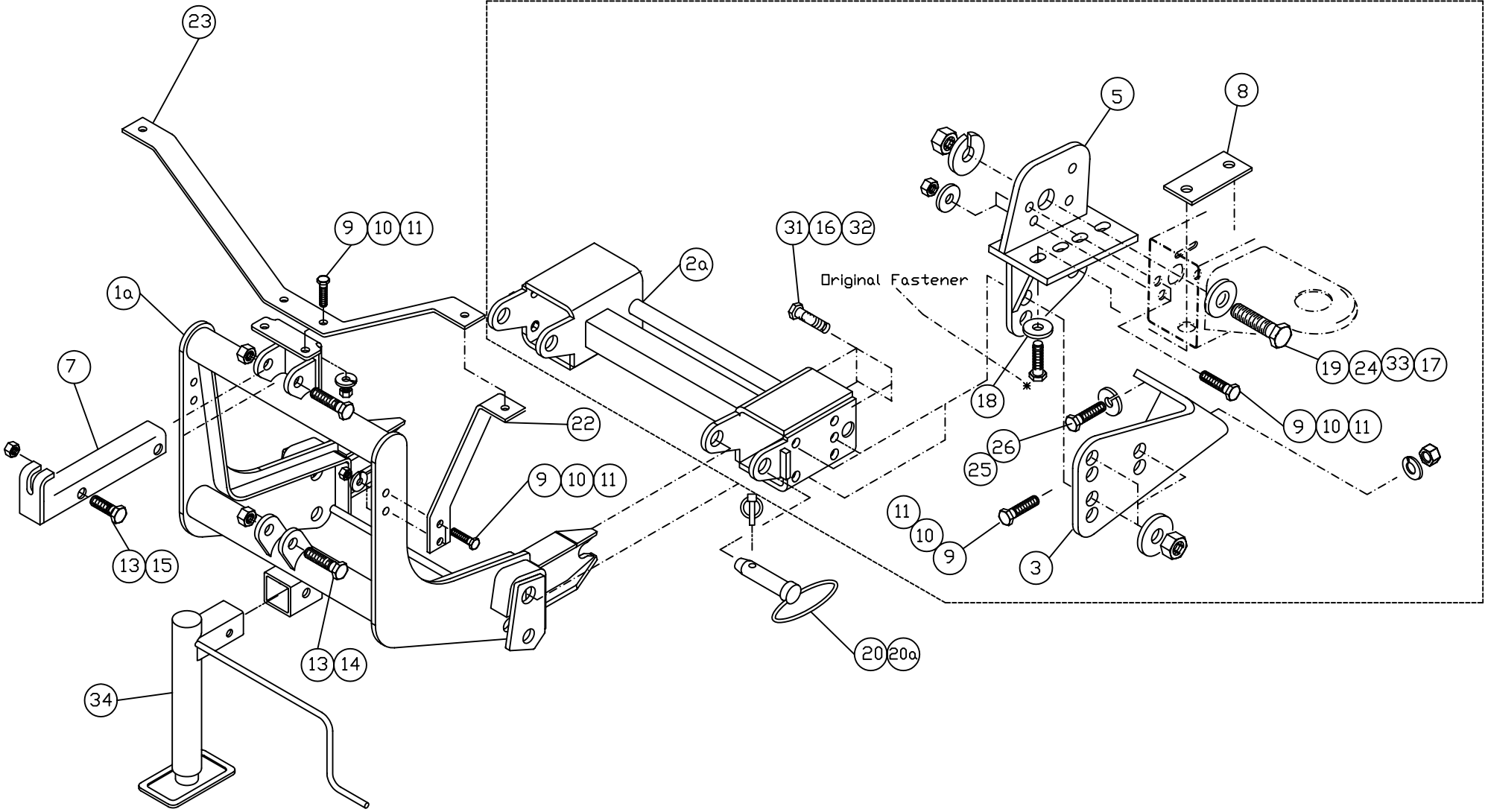

Note:
1. MKPB is shown by dotted lines.
2. All bolts are included in MKPB.

Arctic Equipment Manufacturing Corporation
 Mounting kit 52188-MKPB

52188-MKPB R09
 INST0009

Quik-link Mounting Kit 52188-MKPB								
Item	Part #	Description	MKPB	MKPB-QLII	QL-MKB	QLII-MKB	QLII-HI	QLII-HI-MKB-DLC
1*	52162-C	Lift Frame			1			
1a	52365-D	Lift Frame, QLII				1		
1b*	52430-D	Lift Frame, QLII-Hi boy					1	
2*	52166-C	Spreader Bar	1					
2a	52363-C	Spreader Bar QLII		1				
3	52181-01-B	Thrust Arm Driver Side	1					
4*	52181-02-B	Thrust Arm Curb Side	1					
5	52184-01-B	Mounting Bracket Driver Side	1					
6*	52184-02-B	Mounting Bracket Curb Side	1					
7	50069-C	Lift Channel						
7a*	52612-B	Lift Channel (2" cylinder)					1	
8	52064-A	Back Plate	2					
9	HH-00972-090	½"x1.1/2" UNF Cap screw	12					
10	HH-00457-001	½" Lock washer	16					
11	HH-00460-002	½" UNF Hex Nut	16					
12	HH-00972-091	½"x1.3/4" UNF Cap screw	4					
13	HH-00973-007	3/4" UNF Thin Collar Locknut	3					

Arctic Equipment Manufacturing Corporation
 Mounting kit 52188-MKPB

52188-MKPB R09
 INST0009

Quik-link Mounting Kit 52188-MKPB								
Item	Part #	Description	MKPB	MKPB-QLII	QL-MKB	QLII-MKB	QLII-HI	QLII-HI-MKB-DLC
14	HH-00972-153	3/4"x3.1/2" UNF Cap screw	2					
15	HH-00972-149	3/4"x2.1/2" UNF Cap screw	1					
16	HH-00457-003	5/8" Lock washer	8					
17	HH-00460-007	3/4" UNF Hex Nut	2					
18	HH-00341-006	1/2" Flat washer	4					
19	HH-00972-146	3/4"x1.3/4" UNF Cap screw	2					
20	WA-34704-M	Mounting Pin, QLI, Ass'y			2			
20a	52348-M	Mounting Pin Ass'y					2	
22	52208-B	Light Brace			2			
23	52209-B	Light Antler			1			
24	HH-00341-009	3/4" Flat washer	2					
25	HH-00909-022	M10x35mm Cap screw	2					
26	HH-00933-003	M10 Lock washer	2					
27*	HH-00293-006	1/4"x1" UNC Cap screw	4					
28*	HH-00457-006	1/4" Lock washer	4					
29*	HH-00341-002	1/4" Flat washer	4					
30*	HH-00294-001	1/4" UNC Hex Nut	4					

Arctic Equipment Manufacturing Corporation
 Mounting kit 52188-MKPB

52188-MKPB R09
 INST0009

Quik-link Mounting Kit 52188-MKPB								
Item	Part #	Description	MKPB	MKPB-QLII	QL-MKB	QLII-MKB	QLII-HI	QLII-HI-MKB-DLC
31	HH-00972-132	5/8"x2.1/2" UNF Cap screw	8					
32	HH-00460-001	5/8" UNF Hex Nut	8					
33	HH-00457-008	3/4" Lock Washer	2					
34	52373-M	Jack Assembly					1	
35*	50999-B	Blade guides					2	
36*	HH-00972-155	3/4" x 4" UNF Cap screw						2

Note: * These items are not shown on the drawing.

GENERAL

a)The following information is supplied by General Motors Corporation. For more information refer to your vehicle dealers. Arctic Equipment Manufacturing Corporation does not assume liability for damage to your motor vehicle resulting from following procedure.

Trim height inspection procedure

Trim height measurement

Trim height is a predetermined measurement relating to vehicle ride height. Incorrect trim heights can cause bottoming out over bumps, damage to suspension components and symptoms similar to wheel alignment. Check the trim heights when diagnosing suspension concerns and before checking the wheel alignment problems.

Perform following before measuring the trim heights:

1. Set the tire pressure to the pressure shown on the certification label. Refer to label - vehicle certification in General Information.
2. Check the fuel level. Add additional weight if necessary to simulate a full tank.
3. Make sure the rear compartment is empty except for the spare tire.
4. Make sure the vehicle is on a level surface, such as an alignment rack.
5. Close the doors.
6. Close the hood.
7. All dimensions are measured vertical to ground. Trim heights should be within 13 mm (0.5 in) to be considered correct.

Z height measurement

Important

K models only the Z height must be adjusted before the alignment.

The Z height dimension measurement determines the proper ride height for the front end of vehicle. Vehicle equipped with torsion bars use an adjusting arm in order to adjust the Z height dimension. Vehicles without torsion bars have no adjustments and could require replacement of suspension components.

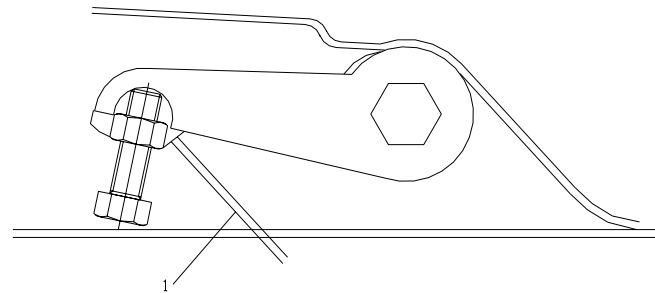

1. Lift the front bumper of the vehicle up about 38 mm (1.5 in).
2. Gently remove your hands.
3. Allow vehicle to settle into position.
4. Repeat this jouncing operation 2 more times for a total of 3 times.

5. Measure from the pivot bolt centre line (3) down to the lower corner (5) of the lower ball joint (1) in order to obtain the Z height measurement (4).

6. Push the front bumper of the vehicle down about 38 mm (1.5 in).

7. Gently remove your hands
8. Allow vehicle to raise
9. Repeat the operation for a total 3 times,

10. Measure the Z dimension.

11. The true Z height dimension number is the average of the high and the low measurements. Refer to trim height specifications.

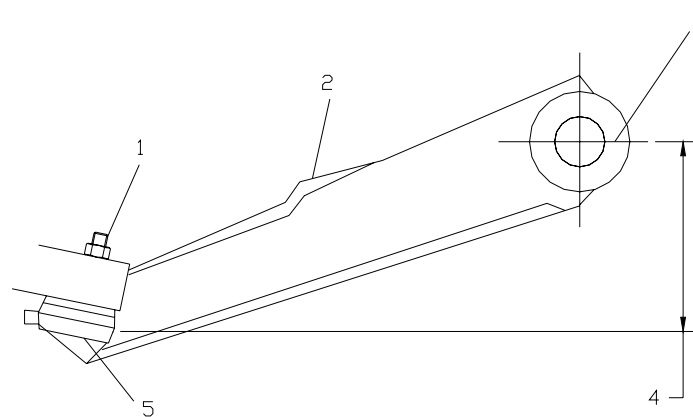

Z height adjustment

1. For vehicle equipped with a torsion bar suspension turn the bolt (1) that contacts the torsion arm clockwise to raise the height adjustment and counterclockwise to lower the height adjustment. One revolution of the bolt (1) into the nut increases the Z height approximately 6 mm (0.2 in).
2. For vehicles without torsion bars, replace damaged or worn components as necessary.

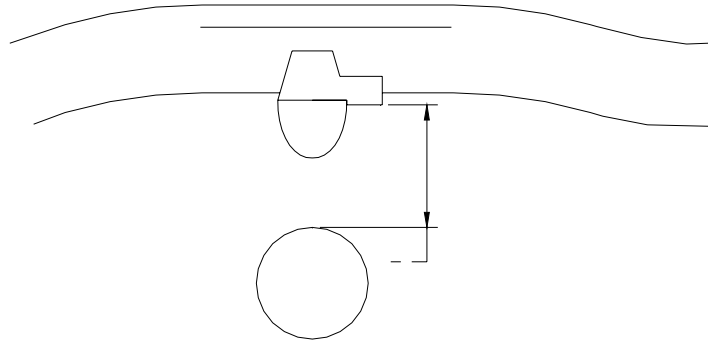

D height measurement

The D height dimension measurement determines the proper rear end ride height. There is no adjustment procedure. Repair may require replacement of suspension components.

1. With the vehicle on flat surface, lift upward on the rear bumper 38 mm (1.5 in)
2. Gently remove your hands. Allow the vehicle to settle into position.
3. Repeat the jouncing operation 2 more times for total of 3 times.
4. Measure the D height by measuring the distance between the bumper bracket and the top of the rear axle tube.
5. Push the rear bumper downward to 38 mm (1.5 in).
6. Gently remove your hands. Allow the vehicle to settle into position.

7. Repeat the jouncing operation 2 more times for total of 3 times.
8. Measure the D height dimension.
9. The true D height dimension number is the average of the high and the low measurement. Refer to trim height specifications.
10. If these measurements are out of specifications, inspect for the following conditions:
 - sagging front suspensions refer to front coil springs replacement or torsion bar replacement in front suspension.
 - sagging rear leaf/coil springs refer to leaf spring replacement or coil spring replacement in rear suspension.
 - worn rear suspension components, such as leaf spring bushings refer to spring bushing replacement in rear suspension.
 - improper tire inflation refer to tire inflation pressure specifications in maintenance and lubrication.
 - improper weight distribution.
 - collision damage.

©Copyright General Motors Corporation. All Rights reserved.

b) **Customer must be aware of following:**

Arctic Equipment Manufacturing Corporation(Arctic) does not assume liability for damage to your motor vehicle resulting from the attachment or use of an Arctic snowplow. The purchaser assumes all vehicle risk associated with the attachment and operation of this snowplow.

The Arctic snowplow you purchase must be used only on vehicles equipped with the manufacturer's snow plow preparation packages. Snow plowing without the original plow preparation package may damage your vehicle. The added weight may impair the operation and control of your vehicle. Snow plowing with a vehicle not recommended for that purpose by the manufacturer may void your new vehicle warranty. If your vehicle is not equipped with an original snow plow preparation package, additional equipment may be necessary before snow plowing. Please consult your vehicle and snowplow dealers prior to the purchase and installation of the snowplow. The installation of such parts however is not a full substitute for the original equipment snowplow preparation package.

Before drilling any holes in the firewall or frame, move brake lines, fuel lines and/or electrical wiring from the path of the drill. Brake and fuel lines must also be clear of any fasteners.

All bolts should be installed from the inside of the truck frame so that the lock washers and nuts are accessible for re tightening.

If a slotted hole in the truck frame is utilized, then a flat washer must be used under the bolt head. If a flatwasher is used under a lock washer use LOCTITE #242. Also use this LOCTITE #242 if existing (vehicle) bolts and nuts are used.

Do not tighten any bolt assemblies until all fasteners and components are installed, unless otherwise specified.

After first use, re tighten all mounting bolts, thereafter check mounting bolt tightness periodically.

For easier installation, grind ONLY the paint out of the top holes of the spreader bar and the top hole of the lift frame, where the mounting pins will go.

Before proceeding, read instructions carefully and familiarize yourself with the components and hardware.

INSTALLATION INSTRUCTIONS

1. DO NOT REMOVE BUMPER, but remove splash guard and tow hooks. Front grill may be removed for easy access of lights.
2. Fasten mounting brackets (5) & (6) to vehicle frame using 3/4" x 1.3/4" bolts (19), flat washer(24), lock washer (33) and hex nut (17).
3. Locate the backing plate (8) inside the truck frame, and fasten mounting bracket to the backing plate with the original fasteners (apply LOCTITE #242) up through the frame. Finger tighten the fastener so that the mounting bracket is snug, up against the truck frame.
Note: If truck does not have tow hook, locate the backing plate (8) inside the truck frame and install two 1/2" x 1 3/4" bolts (12), flat washers (18), lock washers(10) and nuts (11).
Use first and third holes in 2500 series trucks (sloped front edge of frame) and second and fourth holes on 1500 series trucks (perpendicular front edge of frame).



4. Fasten thrust arms (3) & (4) to the truck cross member, using M10x35mm bolt (25), lock washer (26). Apply LOCTITE #242 on the M10 bolt.
5. Fasten spreader bar (2)(2a) using 5/8" x 2.1/2" bolt (31), lock washer (16) and hex nut (32). The spreader pin hole should be located approximately 10-1/2" (+/- 1/2") off the ground for QLI and 14-1/2" (+/- 1/2") for QLII.
Insert 5/8 bolts from inside spreader bar through mounting brackets then through thrust arms. Align all four vertical holes for 2500 series trucks. On 1500 series trucks use top 3 holes in the mounting bracket and the bottom 3 holes of the thrust arm.
6. Drill four 17/32" holes in the truck frame (two in each side, preferable two top or two front holes) using the holes in the mounting bracket (5) & (6) as a guide. Install 1/2" x 1.1/2" bolt (9), lock washer (10) and hex nut (11).
Drill 17/32" hole in the cross member using the hole in the thrust arm as a guide. Install 1/2"x1.1/2" bolt (9), lock washer (10) and hex nut (11).
7. Tighten all hardware.
8. Install lift frame (1). For QLI set hook tabs of lift frame between mounting lugs of spreader bar (2), and lift into position so that the hook tabs are hooked under the cross channel of the spreader bar and resting on the stop tabs on the bottom side of the mounting lugs. For QLII slide lift frame (1a)(1b) inside of spreader bar (2a). Insert mounting pin (20) (20a) in the top holes of the spreader bar (2)(2a).
9. Fasten the light antler (23) to the top of the lift frame (1)(1a), using 1/2" x 1 1/2" bolt lock washer and nut (9), (10), (11). DO NOT TIGHTEN. Fasten the light brace (22) to both sides of the lift frame, using 1/2" x 1 1/2" bolt (9), (10), (11). DO NOT TIGHTEN. Install plow lamps so that the stud is through the light antler and light brace.
10. Tighten all light mounting hardware.
11. Fasten lift channel (7) and lift cylinder or power unit to the lift frame (1)(1a)(1b) using 3/4" x 3.1/2" bolts (14) and 3/4" locknut (13). Use 3/4" x 2.1/2" bolt (15) and 3/4" locknut (13) to attach lift cylinder to lift channel.
NOTE: Do not over tighten as this assembly must be able to pivot.
12. Use 1/4"x1" bolts (27) with lock washer (28), flat washers (29), and hex nuts (30) to fasten blade guides to plow.

Arctic Equipment Manufacturing Corporation

Mounting kit 52188-MKPB

52188-MKPB R09
INST0009

13. Return any unused items to the customer so the vehicle can be returned to its original condition once the snowplow is removed.
14. See separate installation instructions for the hydraulic pump, wiring and controls.

TORQUE CHART (FT. L.B.)		
SIZE	GRADE 5 BOLT 	GRADE 8 BOLT 
$\frac{1}{4}$ - 28	8	11
$\frac{5}{16}$ - 24	15	22
$\frac{3}{8}$ - 24	28	40
$\frac{7}{16}$ - 20	44	63
$\frac{1}{2}$ - 20	69	97
$\frac{5}{8}$ - 18	138	195
$\frac{3}{4}$ - 16	241	341
Note: Torque values are for plated bolts only		